

KCR801ES16

USB 2.0 SD/MMC Card Reader Controller

Datasheet

Document Revision: v1.00

Document Release: Jul, 2022



USB 2.0 SD/MMC Card Reader Controller
Table of Contents

1. Description.....3

2. Features.....3

3. Bock Diagram4

4. Pin Assignment.....5

 4.1 ES16Pin Out Diagram 5

 4.2 ES16Pin Out Description 6

5. Electrical Characteristics7

 5.1 Absolute Maximum Ratings..... 7

 5.2 DC Characteristics and Operating Conditions 7

6. Package Information8

 6.1 ES16Package Dimensions..... 8

1. Description

The KCR801ES16 is a USB 2.0 Card Reader controller by a highly integrated single chip solution designed to deliver high-speed data transmission between USB2.0 and SD, SDHC, miniSD, Micro SD(T-Flash), interfaces specification. The KCR801ES16 is offered with ES16 package.

KCR801ES16 complies with USB specification Rev. 2.0 and USB Mass Storage Class specification Rev. 1.0.

KCR801ES16 integrates an on-chip clock source which provides stable clock source which can be used to replace the external 12MHz crystal oscillator. Manufacturers can effectively reduce the BOM and labor cost on PCBA. KCR801ES16 is the SD card reader with the best C/P value.

2. Features

■ USB

- ◇ Fully compatible with USB 2.0/1.1 specification
- ◇ Support USB 2.0 specification for 480Mbit/sec and 12Mbit/sec operation
- ◇ USB Device Class Definition for Mass Storage , Bulk-Transport v1.0
- ◇ USB 2.0 Bus Power device spec. compliance
- ◇ Endpoint:
 - Endpoint 0: 64 bytes control transfer.
 - Endpoint 1: 512 bytes bulk transfer for IN transaction.
 - Endpoint 2: 512 bytes bulk transfer for OUT transaction.

■ Single Slot support for MMC/SD/MS card

■ MMC/SD card support

- ◇ Support SD 1.1/2.0/SDHC, Micro SD 1.1/2.0/SDHC, Mimi SD card
- ◇ Support SD High Speed Mode
- ◇ Work with the default driver from windows XP//Win7/Win10/W11, Mac OS X+, Linux
- ◇ RedHat, Linux Fedora

■ Integrated 5V to 3.3V/1.8V/1.2V Voltage Regulator

■ Support ES16 package with 4bit SD

■ On-Chip Clock Source to replace external 12MHz external crystal

3. Block Diagram

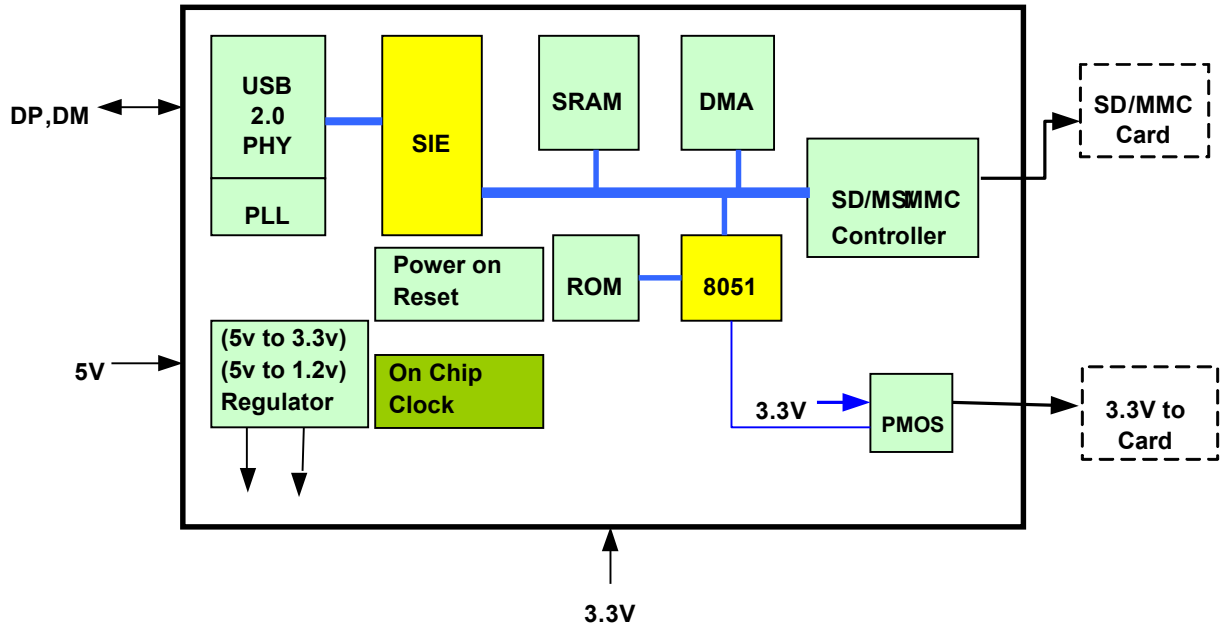

Pin Assignment

3.1 ES16 Pin Diagram

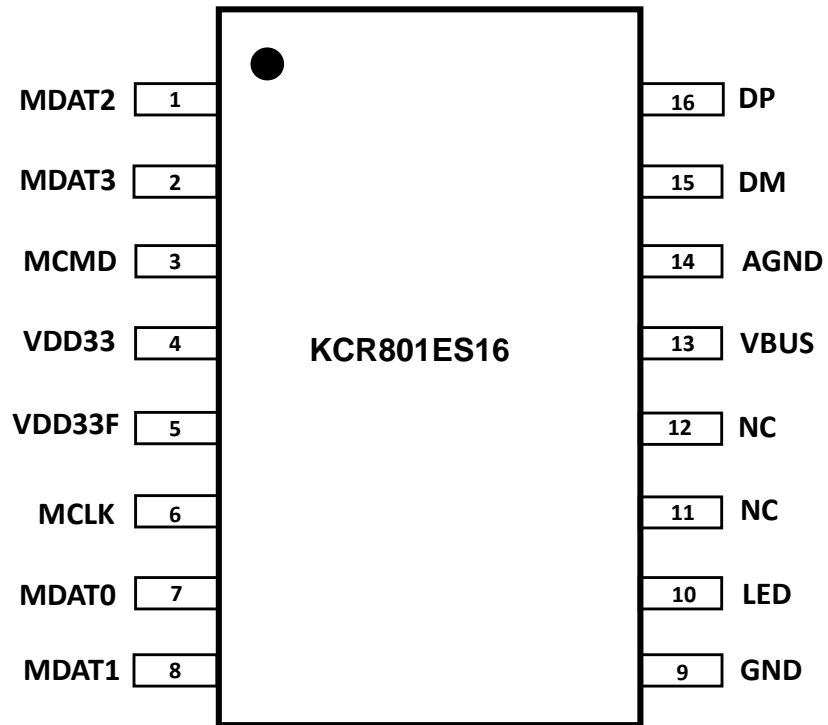

3.2 ES16 Pin Description

Power Pins

Symbol	Pin No.	Type	Description
VDD33	4	P	Logical Power 3.3V output
VDD33F	5	P	Output 3.3V Power Source for SD Card
VBUS	13	P	5V Bus Power Input to Internal Regulator
AGND	14	P	Ground pin
GND	9	P	Ground pin

Analog and Others Pins

Symbol	Pin No.	Type	Description
LED	10	O	LED for operation status indicator
DM	15	A	USB D- for high/full speed
DP	16	A	USB D+ for high/full speed

SD/MMC/MS Interface

Symbol	Pin No.	Type	Description
MDAT [0:3]	7,8,1,2	I/O	SD/MMC data pin
MCMD	3	O	SD/MMC command response pin
MCLK	6	O	SD/MMC clock output

NC

Symbol	Pin No.	Type	Description
NC	11,12	I/O	Not used. (Leave open)

USB 2.0 SD/MMC Card Reader Controller

4. Electrical Characteristics

4.1 Absolute Maximum Ratings

Parameter	Value
Supply Voltage	-0.5V to +6.0V
Operating Temperature Range	0°C to +70°C

4.2 DC Characteristics and Operating Conditions

Symbol.	Parameter	Rating			Unit
		Min.	Typ.	Max.	
V_{bus}	5V Power Supply Voltage	4.5		5.5	V
V_{IH}	High level input voltage	2.0			V
V_{IL}	Low level input voltage			0.8	V
V_{OH}	High level output voltage	3.0			V
V_{OL}	Low level output voltage			0.4	V
I_{OH}	High level output current	6			mA
I_{OL}	Low level output current (V_{OL} = 0.4V)	6			mA

5. Package Information

5.1 ES16 Package

封装尺寸图

Dimensions

ES16 (Bodysize:4.7*3mm Pitch:0.53mm)

尺寸 标注	最小 (mm)	最大 (mm)	尺寸 标注	最小 (mm)	最大 (mm)
A	4.50	4.70	C	0.85	1.05
A1	0.29	0.39	C1	0.00	0.15
e	0.53 (BSC)		C2	0.15	0.18
B	2.50	2.70	L	0.40	0.60
B1	3.85	4.15	θ	0°	8°
b	0.16	0.26			

