

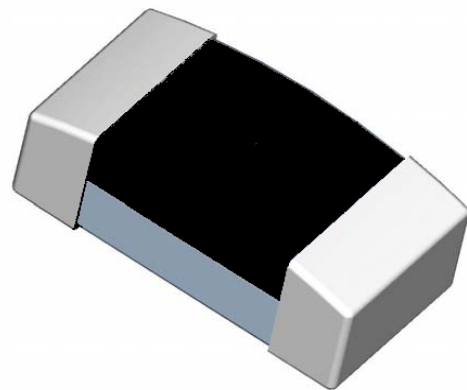
**ESD Protector**  
Overvoltage Protection Device

**BENEFITS**

- ESD protection for high frequency applications (HDMI 1.3)
- Smaller form factor for board space savings
- Helps protect electronic circuits against damage from electrostatic discharge (ESD) events
- Assists equipment to pass IEC 61000-4-2, level 4 testing

**FEATURES**

- 0.15 pF (typ) Capacitance
- Low leakage current
- Low clamping voltage
- Fast response time (<1ns)
- Capable of withstanding numerous ESD strikes
- Compatible with standard reflow installation procedures
- Thick film technology
- Bi-directional protection



**APPLICATIONS**

- HDMI 1.3 interface
- LCD, HDTV
- Cellular phones
- Antennas (cell phones, GPS...)
- Portable video devices (PDA, DSC, Bluetooth...)
- Printer ports
- High speed Ethernet
- USB 2.0 and IEEE 1394 interfaces
- DVI interface

**CAUTION:** This device should not be used in Power Bus applications

**MATERIALS INFORMATION**

**RoHS Compliant**

Directive 2002/95/EC  
Compliant

**ELV Compliant**

Directive 2000/53/EC  
Compliant

**Halogen Free\***



**Lead Free**



\* Halogen Free refers to: Br≤900ppm, Cl≤900ppm, Br+Cl≤1500ppm



**TYPICAL DEVICE RATINGS AND CHARACTERISTICS**

Symbol	Continuous Max Operating Voltage	Typical TLP Trigger Voltage <sup>1</sup>	Typical TLP Clamping Voltage <sup>1</sup> after 30ns	Typical Capacitance <sup>2</sup> @ 1 MHz, 1V <sub>rms</sub>	Typical Leakage Current @14V <sub>DC</sub>	Max Leakage Current @14V <sub>DC</sub>
	V <sub>DC</sub>	V <sub>T(TLP)</sub>	V <sub>C(TLP 30)</sub>	Cp	I <sub>L(Typ)</sub>	I <sub>L(MAX)</sub>
Unit	V	V	V	pF	μA	μA
Value	5	250	40	0.15	<0.01	10.0

Note 1: TLP test method at 1000V (refer to FIG. 5 on page 5)

Note 2: Typical capacitance @ 0V and 14V bias

**GENERAL CHARACTERISTICS**

Operating temperature: -55°C to +125°C

Storage temperature: -40°C to +85°C

ESD voltage capability (tested per IEC 61000-4-2)

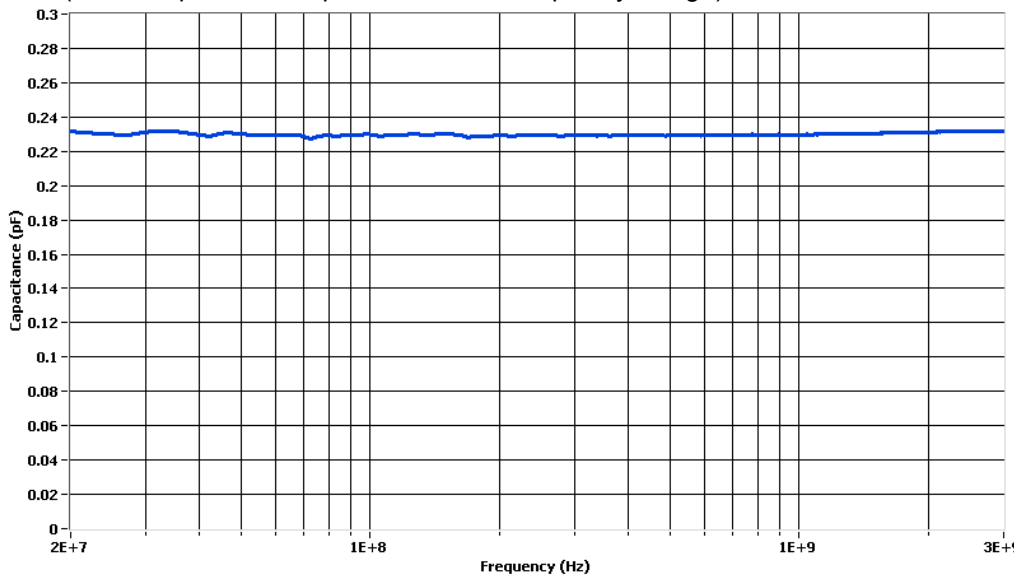
- Contact discharge mode: 8kV (typ), 15kV (max)
- Air discharge mode: 15kV (typ), 25kV (max) [1 pulse: per customer request]

ESD pulse withstand: Typically 100 pulses (tested per IEC 61000-4-2, level 4, and contact method)

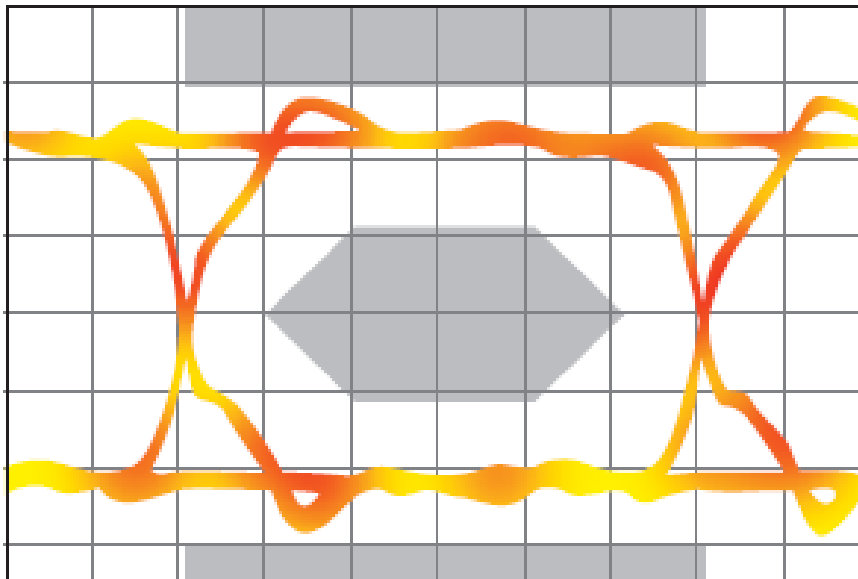
**Environmental Specifications**

Test Conditions	Bias Humidity Test	Thermal Shock	Bias Heat Test	Bias Low Temp Test	Solderability	Solder Heat	Vibration	Mechanical Shock	Solvent Resistance
	@ 85°C @ 85% RH V <sub>DC</sub> (max) 1000 hours	-55°C to 125°C 30min dwell 1000 cycles	@ 125°C V <sub>DC</sub> (max) 1000 hours	@ -55°C V <sub>DC</sub> (max) 1000 hours	250°C +/- 5°C 3s +/- 1s	260°C, 10s	10 to 50Hz, 60s cycle, 2hrs each in X-Y-Z axis	1500G, 0.5ms, X-Y-Z axis 3 times	IPA ultrasonic 300s
Pass/Fail Criteria	I <sub>L</sub> ≤ 10μA	I <sub>L</sub> ≤ 10μA	I <sub>L</sub> ≤ 10μA	I <sub>L</sub> ≤ 10μA	95% coverage	90% coverage	No Physical Damage I <sub>L</sub> ≤ 10 μA	No Physical Damage I <sub>L</sub> ≤ 10 μA	No Physical Damage I <sub>L</sub> ≤ 10 μA

**FIG 1: CAPACITANCE VS. FREQUENCY (TYPICAL SAMPLE)**  
( Flat Response of Capacitance over Frequency Range)

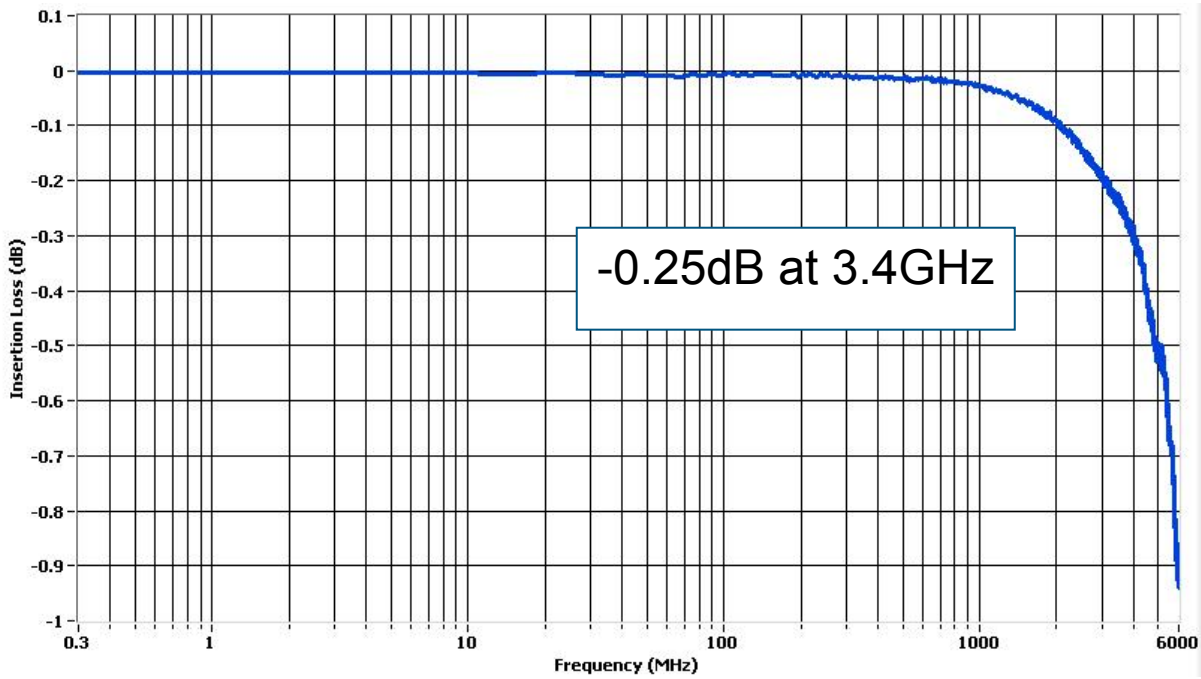


**FIG 2: EYE DIAGRAM (TYPICAL SAMPLE)**  
( Eye Diagram Performance at 3.4 GHz— meets criteria for HDMI 1.3)



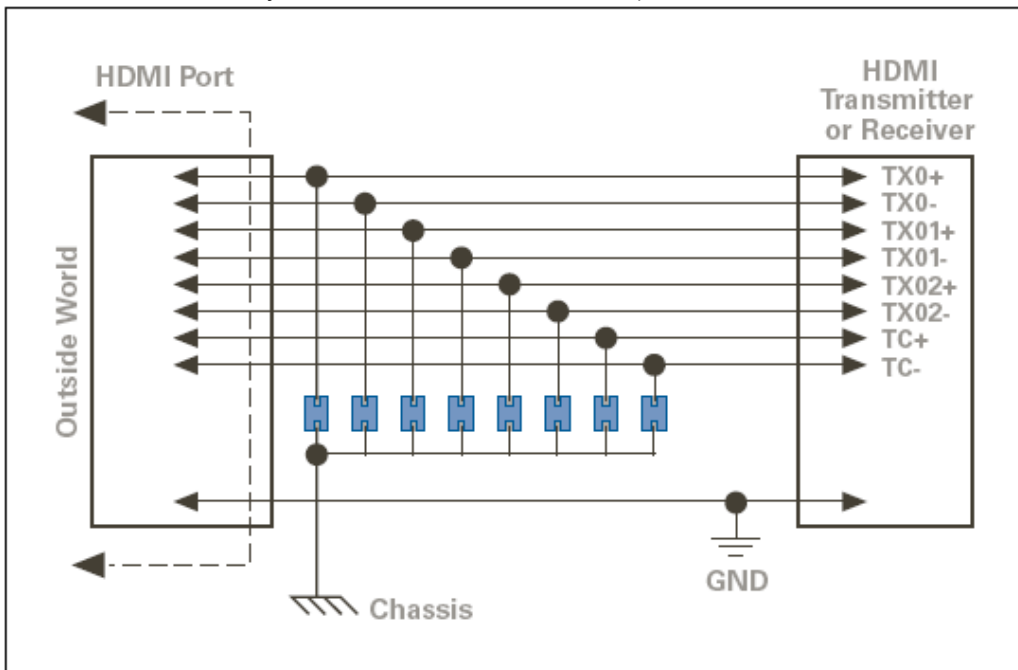
**FIG 3: INSERTION LOSS DIAGRAM (TYPICAL SAMPLE)**

(Minimal Insertion Loss at 3.4 GHz)



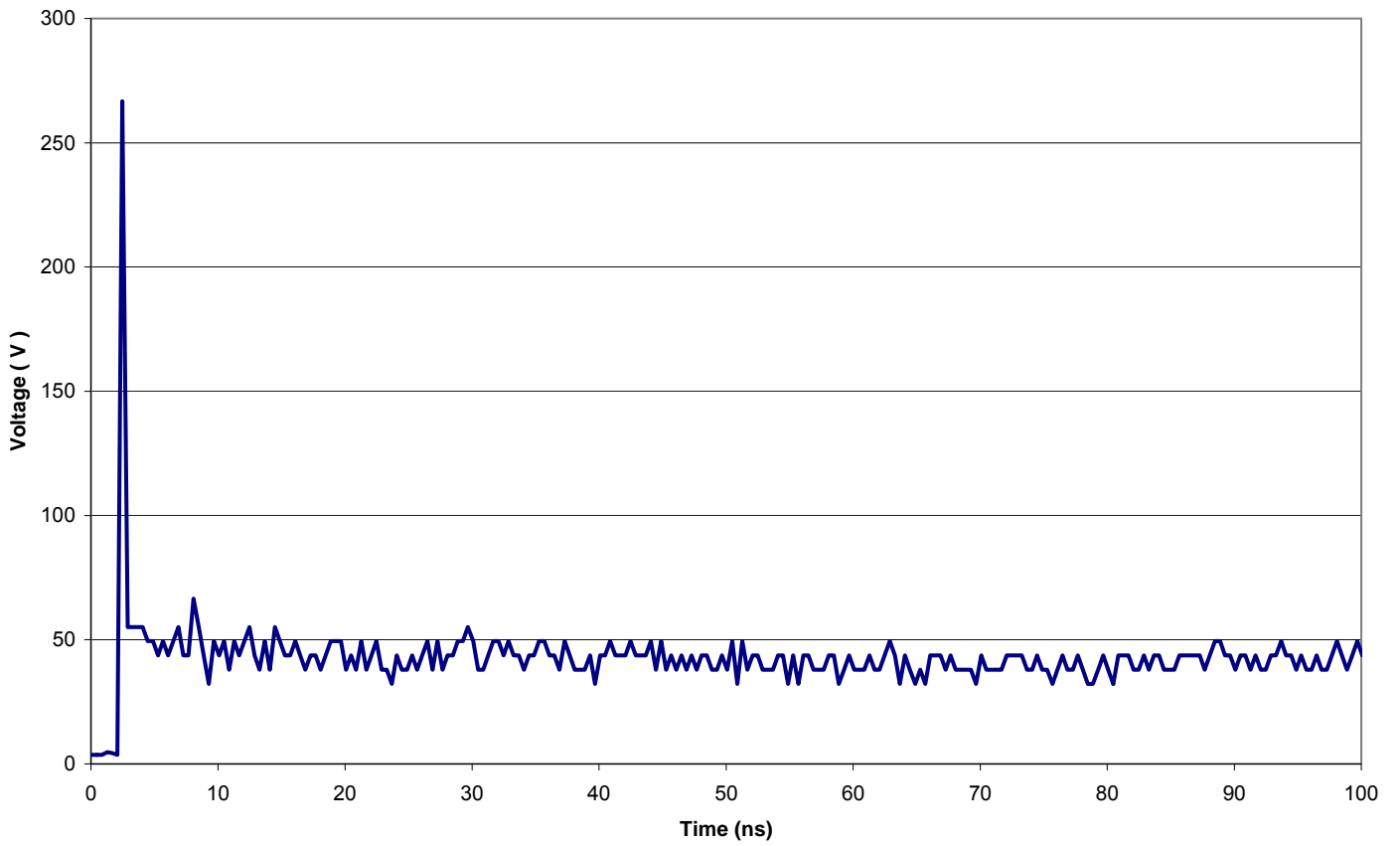
**FIG 4: ESD PROTECTION FOR HDMI**

(Reference Layout and Test Results available)



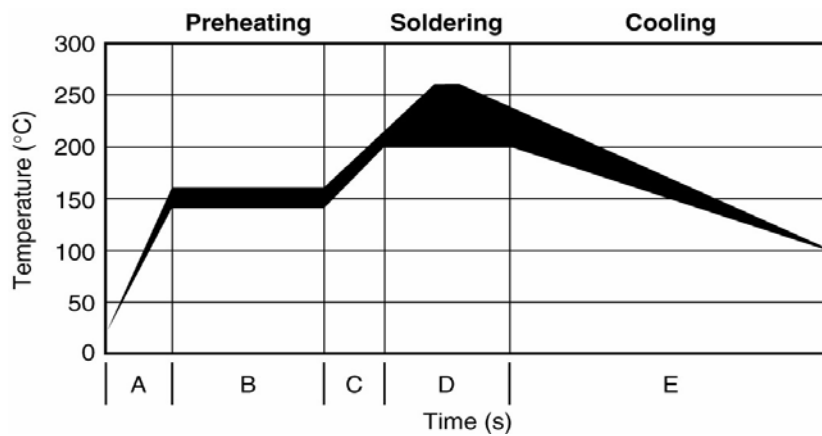
**FIG 5: TYPICAL TRANSMISSION LINE PULSE RESPONSE GRAPH**

**Typical TLP Clamping Voltage**

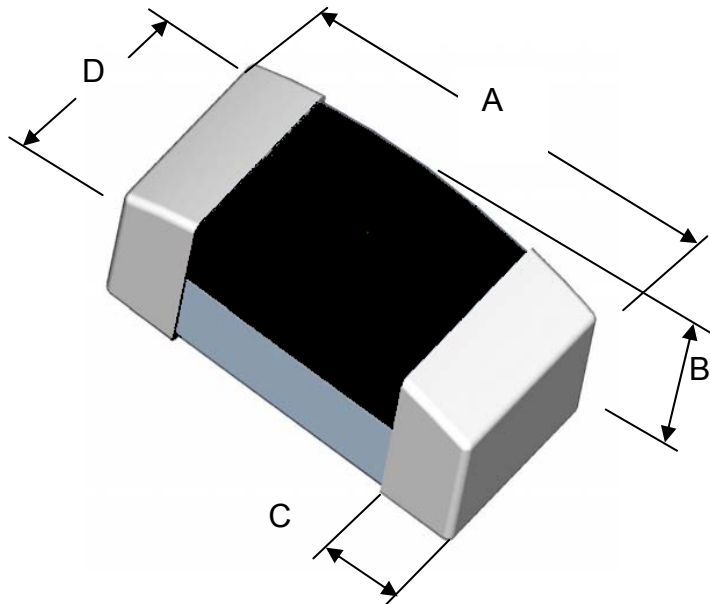


**SOLDER REFLOW RECOMMENDATIONS:**

A	Temperature ramp up 1	From ambient to Preheating temperature	30s to 60s
B	Preheating	140°C - 160°C	60s to 120s
C	Temperature ramp up 2	From Preheating to Main heating temperature	20s to 40s
D	Main heating	at 200°C at 220°C at 240°C at 260°C	60s ~ 70s 50s ~ 60s 30s ~ 40s 5s ~ 10s
E	Cooling	From main heating temperature to 100°C	4°C/s (max)



**DIMENSIONS**

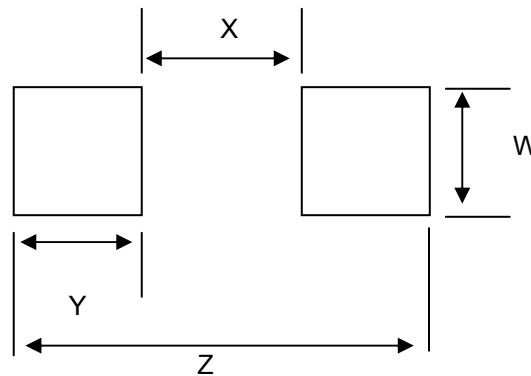


Drawing Not To Scale

	Length A		Height B		Terminal Width C		Width D	
	Min	Max	Min	Max	Min	Max	Min	Max
mm	1.50	1.70	0.40	0.60	0.20	0.40	0.70	0.90
in*	(0.059)	(0.067)	(0.016)	(0.024)	(0.008)	(0.016)	(0.027)	(0.035)

\* Round off approximation

**RECOMMENDED LAND PATTERN:**



	W		X		Y		Z	
	Min	Max	Min	Max	Min	Max	Min	Max
mm	0.90	1.00	0.50	0.60	1.00	1.10	2.70	2.80
in*	(0.035)	(0.039)	(0.020)	(0.024)	(0.039)	(0.043)	(0.106)	(0.110)

\* Round off approximation