



## Electromotive 2 way angle seat control valve

- Good and fast control
- Weather, impact and vibration resistant design
- Easy cleaning by its design according hygienic demands
- Position controller and process controller available

Product variants described in the data sheet may differ from the product presentation and description.

### Can be combined with

	<b>Type 3320</b> Electromotive 2/2 way angle seat valve (ON/OFF)	▶
	<b>Type 3321</b> Electromotive 2/2 way globe valve (ON/OFF)	▶
	<b>Type 3361</b> Electromotive 2 way globe control valve	▶
	<b>Type 8098</b> FLOWave SAW flow-meter	▶
	<b>Type ME43</b> Fieldbus gateway	▶

### Type description

The innovative process controller Bürkert valve Type 3360 is the solution when it comes to control tasks under demanding operating conditions.

The electromotive actuator with ball screw positions the control cone with highest precision. A unique feature is its high positioning speed up to 6 mm/s, that reacts quasi delay-free to process signals, and can be varied according to customer demands. Pressure variations or shocks in the medium aren't transferred to the valve position. If necessary, the safety position can be approached by an optional energy storage in case of power failure.

Actuator and valve are adapted perfectly to each other with closed design and robust surface. This ensures the hygienic requirements of a fast and residue-free cleaning.

Harsh environments are no problem for the Type 3360 because of the protection class IP65 / IP67 and its high impact and vibration resistance. Unrivalled cycle life and sealing integrity is guaranteed by the proven self adjusting spindle packing with exchangeable V-seals.

The fieldbus suitable Type 3360 provides many helpful functions for process monitoring, valve diagnostics and predictive maintenance and thus offers the decisive advantage of a modern process automation.

## Table of contents

<b>1. General technical data</b>	<b>3</b>
<b>2. Approvals</b>	<b>5</b>
<b>3. Materials</b>	<b>6</b>
3.1. Chemical Resistance Chart – Bürkert resistApp.....	6
3.2. Material specifications.....	6
<b>4. Dimensions</b>	<b>8</b>
4.1. Actuator .....	8
AG2 .....	8
AG3 .....	10
4.2. Body with threaded connection.....	12
4.3. Body with welded connection .....	13
4.4. Body with clamp connection .....	14
<b>5. Performance specifications</b>	<b>15</b>
5.1. Fluidic data .....	15
Flow characteristics .....	15
Overview of flow characteristics with flow below seat .....	15
5.2. Operating limits.....	16
Operating limits for medium temperature and operating pressure.....	16
Operating limits for ambient and medium temperature .....	17
Operating limits for seat seal .....	18
Operating limits for optional versions .....	18
5.3. Electrical control and interfaces .....	19
Interface diagram.....	19
<b>6. Product design and assembly</b>	<b>20</b>
6.1. Product features .....	20
6.2. Product assembly .....	22
AG2 .....	22
AG3 .....	23
<b>7. Ordering information</b>	<b>24</b>
7.1. Bürkert eShop – Easy ordering and quick delivery.....	24
7.2. Bürkert product filter.....	24
7.3. Ordering chart accessories.....	24
Standard accessories .....	24
Accessories cable.....	24
Bürkert accessories .....	25
7.4. Bürkert product enquiry form .....	25

## 1. General technical data

### Note:

- **AG2:** Actuator size 2 with a nominal force of 1300 or 2500 N for seat size 15...50
- **AG3:** Actuator size 3 with a nominal force of 7700 or 10000 N for seat size 40...65

Product properties	
Dimensions	Detailed information can be found in chapter <a href="#">“4. Dimensions” on page 8.</a>
Material	Detailed information can be found in chapter <a href="#">“3. Materials” on page 6.</a>
Design	Angle seat control valve
Nominal diameter	DN 15...65, NPS ½...2 ½
Safety setting in case of power failure	With SAFEPOS energy-pack: open, closed or freely programmable Without SAFEPOS energy-pack: blocked in last position
Flow direction	Against closing direction (below seat)
Controller versions	Position controller or process controller (optional)
Weight	Actuator depending on version up to: AG2: 5.5 kg AG3: 16 kg (Total weight including valve body depending on port connection)
Performance data	
Operating pressure	0...25 bar(g) (see <a href="#">“5.1. Fluidic data” on page 15</a> ) Vacuum version up to -0.9 bar(g) (optional)
Nominal pressure	PN 25 (DIN EN 1333), Class 150 (DIN EN 1759)
K <sub>vs</sub> value	5.0...90 m <sup>3</sup> /h (see <a href="#">“5.1. Fluidic data” on page 15</a> )
Flow characteristic	Modified equal percentage (see <a href="#">“5.1. Fluidic data” on page 15</a> )
Seat leakage (DIN EN 60534 - 4)	Class III, IV and VI (see <a href="#">“5.1. Fluidic data” on page 15</a> )
Closing time <sup>1)</sup>	AG2: 2.3...6.6 s AG3: 8.7 s (Depending on travel speed, stroke and operating conditions)
Travel speed <sup>1)</sup>	6 mm/s (for AG2 actuator force 1300 N) 4 mm/s (for AG2 actuator force 2500 N) 3 mm/s (for AG3 actuator load 7700 N and 10000 N) (Depending on operating conditions)
Dead band of the position control	±0.1 %
Electrical data	
Operating voltage	24 V DC ± 10 % (max. residual ripple 10 %)
Operating current <sup>1)</sup>	AG2: Max. 3 A (at max. load and including 1 A charging current of the optional SAFEPOS energy-pack). At minimum operating temperature additionally 2 A AG3: Max. 5 A (at max. load and including charging current of the optional SAFEPOS energy-pack). At minimum operating temperature additionally 6 A
Protection class (DIN EN 61140)	3
Duty cycle	100 %
Standby consumption <sup>1)</sup>	2...5 W
Communication and control	
Standard signal (analogue)	Setpoint: 0/4...20 mA, 0...5/10 V and digital input (further inputs and outputs optional, see <a href="#">“5.3. Electrical control and interfaces” on page 19</a> )
Fieldbus (digital)	Bürkert system bus (bÜS) CANopen (optional) EtherNet/IP, PROFINET, Modbus/TCP (optional via integrated gateway)
Media data	
Process medium	Steam, neutral gases, water, alcohols, oils, fuels, hydraulic fluids, salt solutions, lyes, organic solvents, oxygen (optional)
Medium temperature	-40 °C...+230 °C (see <a href="#">“5.2. Operating limits” on page 16</a> )
Viscosity	Up to 600 mm <sup>2</sup> /s

**Process/Port connection & communication****Port connection<sup>2)</sup>**

Welded connection	DIN EN ISO 1127/ISO 4200/DIN11866 B DIN 11850 2/DIN 11866 A ASME BPE/DIN 11866 C SMS 3008
Clamp connection	DIN 32676 B (pipe ISO 4200) DIN 32676 A (pipe DIN 11850 2) ASME BPE
Threaded connection	G (EN ISO 228-1) Rc (ISO 7/1 /DIN EN 10226-2) NPT (ASME B 1.20.1)

**Electrical connection**

Actuator	Terminal strip with cable gland, 3 x M20 (only AG2) or 2 M12 circular plugs, 5 pin and 8 pin, 1 M12 circular socket, 5 pin (only for process controller function)
Fieldbus gateway	2 M12 circular sockets, 4 pin (only with Industrial Ethernet)

**Approvals and certificates**

Conformity	Food EGV 1935/2004 FDA (optional)
Approval	Explosion protection ATEX/IECEx (optional) (see <a href="#">“2. Approvals” on page 5</a> ) cULus Cert. No. 238179 (optional) (only AG2) (see <a href="#">“2. Approvals” on page 5</a> )
Ignition protection class	II 3G Ex ec IIC T4 Gc II 3D Ex tc IIIC T135 °C Dc
Detergent resistance	According to Ecolab test method: R&D/P3-E No. 40-1









**Environment and installation**

Ambient temperature	-25...+65 °C (only without additional modules) (Derating see <a href="#">“Operating limits for ambient and medium temperature” on page 17</a> )
Degree of protection	IP65/IP67 (DIN EN 60529), NEMA 4X (only AG2)
Installation position	Any, preferably actuator face up

1.) All values refer to a supply voltage of 24 V at 25 °C.

2.) Others on request

## 2. Approvals

Approvals/ Conformity/ Certificate	Description
	<b>Food produce contact</b> Materials in contact with medium conform to EC regulation 1935/2004 Materials in contact with medium conform to FDA (optional)
	<b>Drinking water</b> Suitable for use with drinking water according to KTW, W270 (optional)
	<b>Oxygen</b> Suitable for use with gaseous oxygen (optional)
 	<b>Explosion proof</b> As category 3 device suitable for zone 2/22 (optional)  <b>ATEX</b> <ul style="list-style-type: none"> <li>• II 3G Ex ec IIC T4 Gc</li> <li>• II 3D Ex tc IIIC T135 °C Dc</li> </ul> <b>IECEX</b> <ul style="list-style-type: none"> <li>• Ex ec IIC T4 Gc</li> <li>• Ex tc IIIC T135 °C Dc</li> </ul>
	<b>Safety requirements</b> UL-listed cULus Cert. No. 238179 (optional) (only AG2)
	<b>Detergent resistance</b> Material compatibility tested with common Ecolab products and certified according to Ecolab test method: R&D/P3-E No. 40-1
Standards	Description
	Field device for integration into the EDIP platform via Bürkert system bus (büS)

### 3. Materials

#### 3.1. Chemical Resistance Chart – Bürkert resistApp

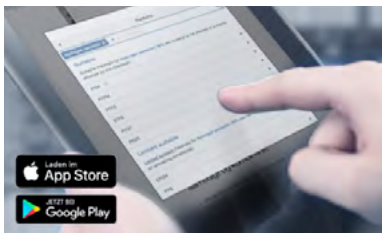

**Bürkert resistApp – Chemical Resistance Chart**

You want to ensure the reliability and durability of the materials in your individual application case? Verify your combination of media and materials on our website or in our resistApp.

[Start Chemical Resistance Check](#)

#### 3.2. Material specifications

**Note:**

The Type 3360 angle seat valve is supplied with various port connections (thread, weld end and clamp connections). These connections are not shown. They are the same material as the valve body.

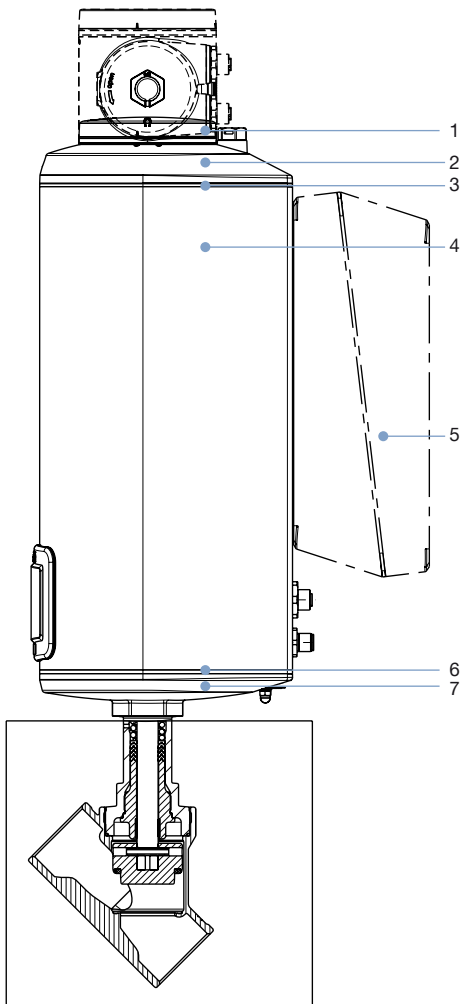

**AG2**

No.	Component	Material
1	Display housing/Blind cover /Gateway housing	PPS (Standard), Stainless steel 1.4301 (for ATEX/IECEX)
2	Actuator cover	PPS
3	Seal	EPDM
4	Actuator housing	Aluminium powder coated
6	Seal	EPDM
7	Actuator base	PPS

**AG3**

No.	Component	Material
1	Display housing/Blind cover /Gateway housing	PPS (Standard), Stainless steel 1.4301 (for ATEX/IECEX)
2	Actuator cover	PC
3	Seal	EPDM
4	Actuator housing	Aluminium powder coated
5	SAFEPOS energy pack	PC
6	Seal	EPDM
7	Actuator base	Stainless steel 1.4308

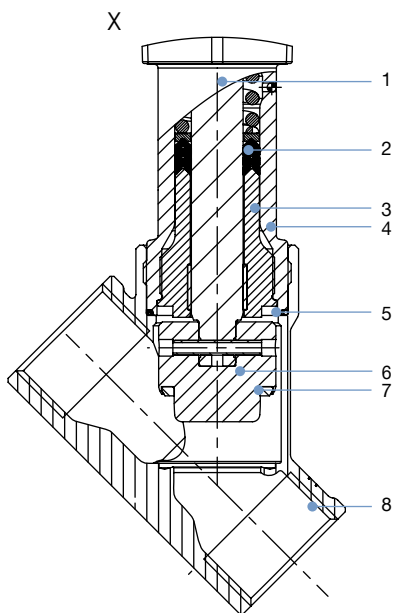

No.	Component	Material
1	Spindle	Stainless steel 1.4401 (316)/1.4404 (316L)
2	Spindle seal	PTFE V-seals (filled) with spring compensation
3	Spindle guidance	Stainless steel 1.4404 (316L)
4	Packing gland tube	Stainless steel 1.4401 (316)
5	Seal valve body	Graphite or PTFE
6	Control cone	Stainless steel 1.4571
7	Seat seal	Stainless steel 1.4571/PTFE or PEEK seal washer
8	Valve body	Stainless steel CF3M

## 4. Dimensions

### 4.1. Actuator

AG2

**Note:**

Dimensions in mm, unless otherwise stated

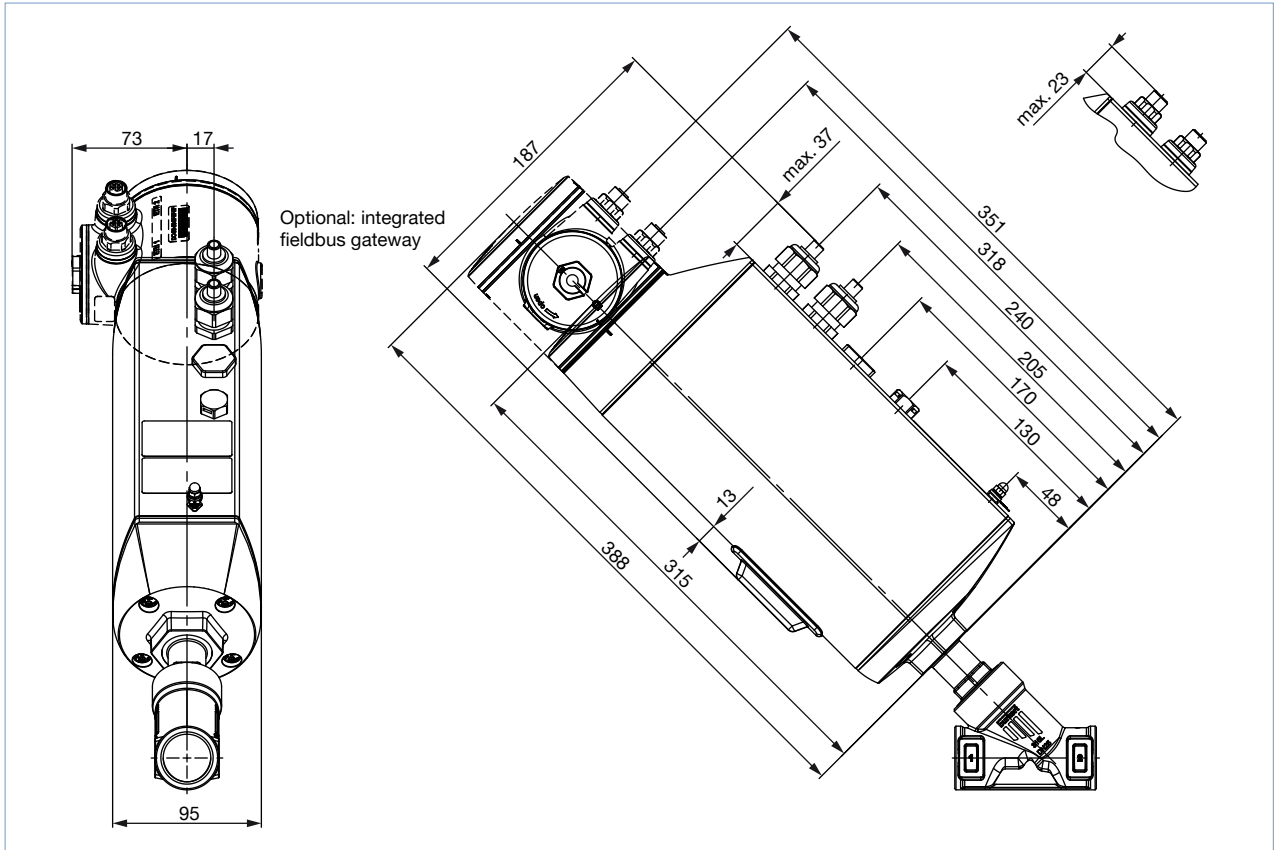



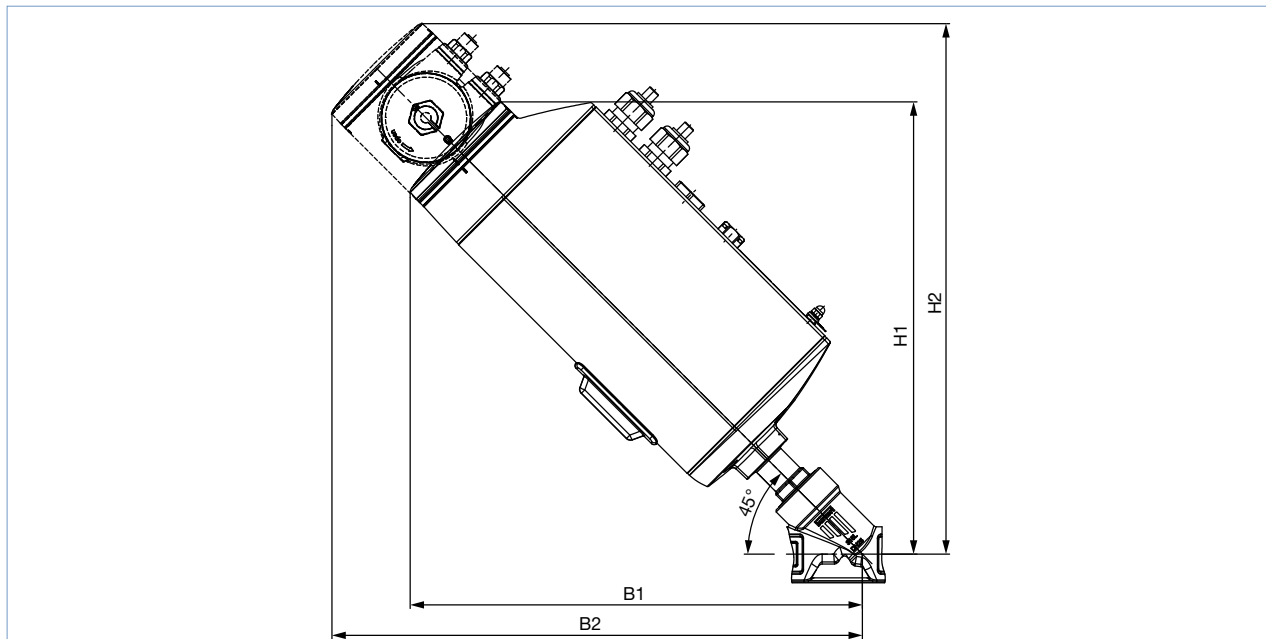

Nominal diameter (Pipe)		Height/Width <sup>1.)</sup>	
DN	NPS	H1/B1 Standard version	H2/B2 <sup>2.)</sup> Fieldbus version (KOMM ≠ G, N, L)
15	1/2	311	362
20	3/4	319	369
25	1	334	385
32	1 1/4	349	399
40	1 1/2	352	403
50	2	367	418

1.) Dimensions without tight-closing function: in closed position the actuator additionally lifts by approx. 2 mm

2.) Optional: integrated fieldbus gateway

AG3

Note:

Dimensions in mm, unless otherwise stated

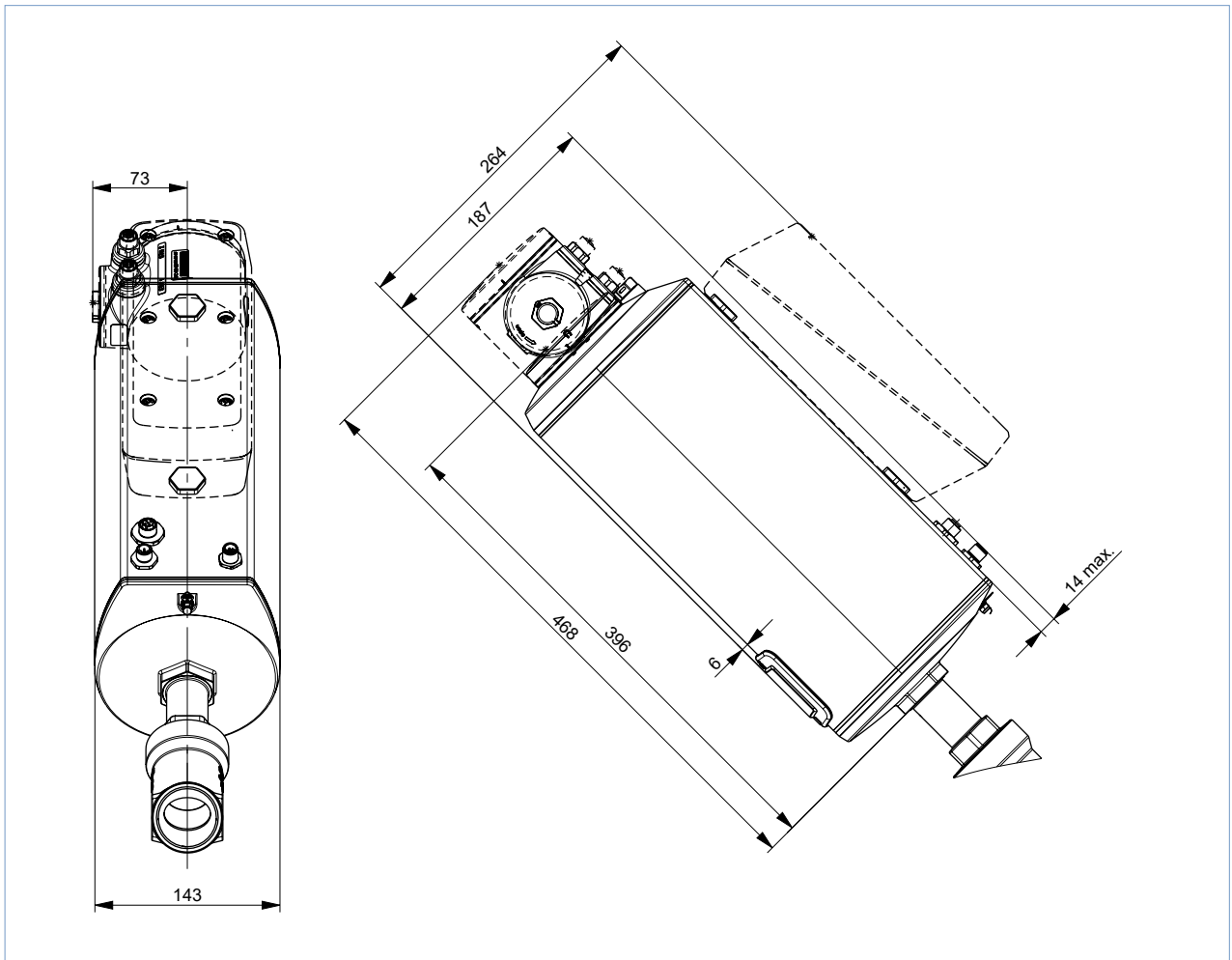

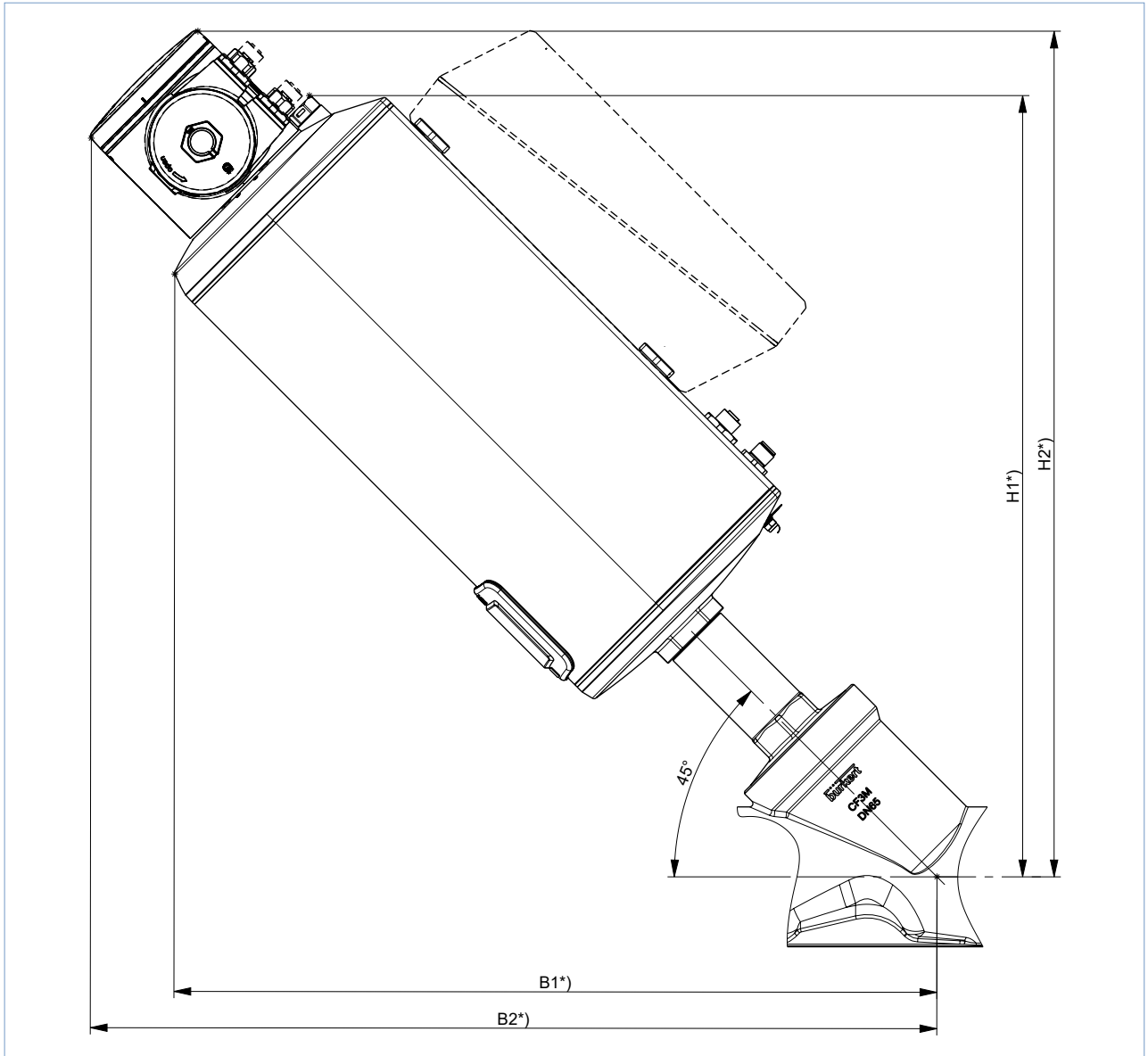

Nominal diameter (Pipe)		Height/Width <sup>1.)</sup>	
DN	NPS	H1/B1 Standard version	H2/B2 <sup>2.)</sup> Fieldbus version (KOMM ≠ G, N, L)
40	1½	439	479
50	2	454	494
65	2½	467	507

1.) Dimensions without tight-closing function: in closed position the actuator additionally lifts by approx. 2 mm

2.) Optional: integrated fieldbus gateway

4.2. Body with threaded connection

**Note:**

Dimensions in mm, unless otherwise stated

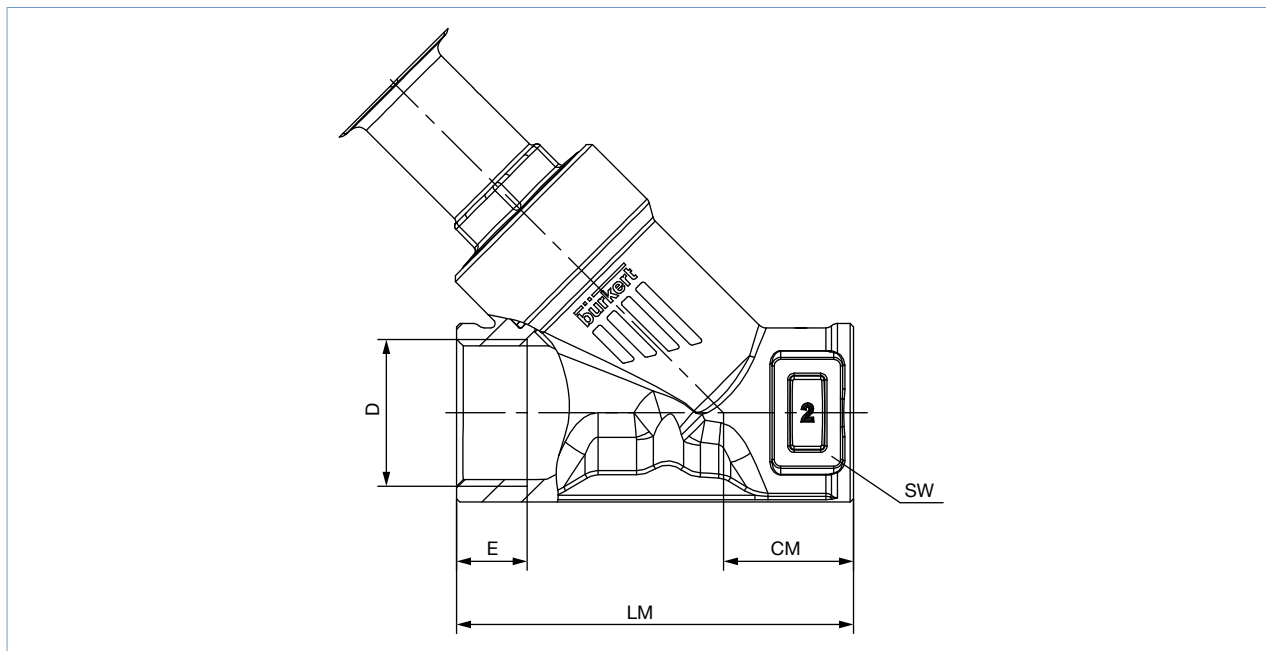

Nominal diameter (Pipe)	G (DIN ISO 228 - 1), NPT (ASME B 1.20.1), Rc (ISO7 - 1)				CM	LM	SW
	D	E					
DN	NPS	G	NPT	Rc			
15	½	14	13.7	13.2	24	65	27
20	¾	16	14.0	14.5	27	75	34
25	1	18	16.8	16.8	29.5	90	41
32	1¼	16	17.3	19.1	36	110	50
40	1½	18	17.3	19.1	35	120	55
50	2	24	17.6	23.4	45	150	70
65	2½	26	23.7	26.7	57	185	85

DTS 1000273502 EN Version: U Status: RL (released | freigegeben | validé) printed: 28.02.2023

### 4.3. Body with welded connection

**Note:**

Dimensions in mm, unless otherwise stated

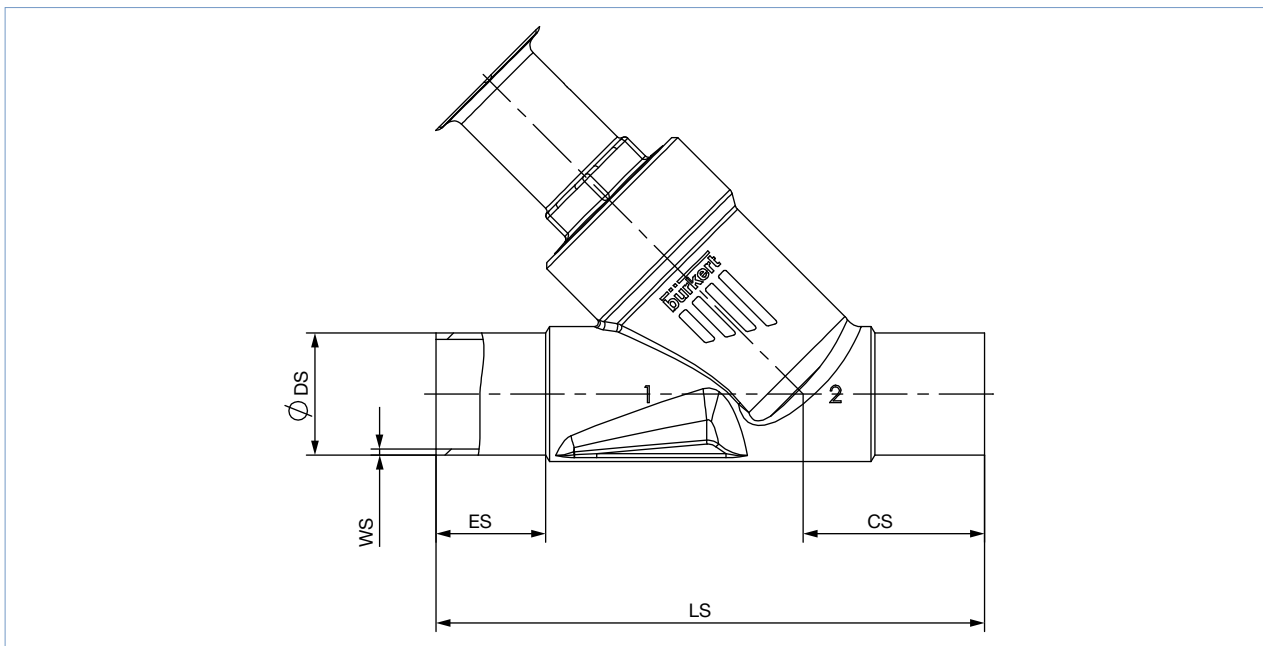

Nominal diameter (Pipe)	DIN EN ISO 1127 ISO 4200 DIN 11866 B					DIN 11850 2 DIN 11866 A				
	DN	ES	CS	LS	ØDS	WS	ES	CS	LS	ØDS
15	19	34	100	21.3	1.6	19	34	100	19	1.5
20	20	39	115	26.9	1.6	20	39	115	23	1.5
25	26	43	130	33.7	2.0	26	43	130	29	1.5
32	26	45	145	42.4	2.0	26	45	145	35	1.5
40	26	49	160	48.3	2.0	26	49	160	41	1.5
50	26	50	175	60.3	2.0	26	50	175	53	1.5
65	26	50	210	76.1	2.3	26	50	210	70	2

Nominal diameter (Pipe)	ASME BPE DIN 11866 C				
	NPS	ES	CS	LS	ØDS
1/2	30	46	135	12.7	1.65
3/4	30	52	145	19.05	1.65
1	30	51	152	25.4	1.65
1 1/2	30	60	182	38.1	1.65
2	30	64	210	50.8	1.65
2 1/2	26	56	230	63.5	1.65

DTS 1000273502 EN Version: U Status: RL (released | freigegeben | validé) printed: 28.02.2023

#### 4.4. Body with clamp connection

**Note:**  
Dimensions in mm

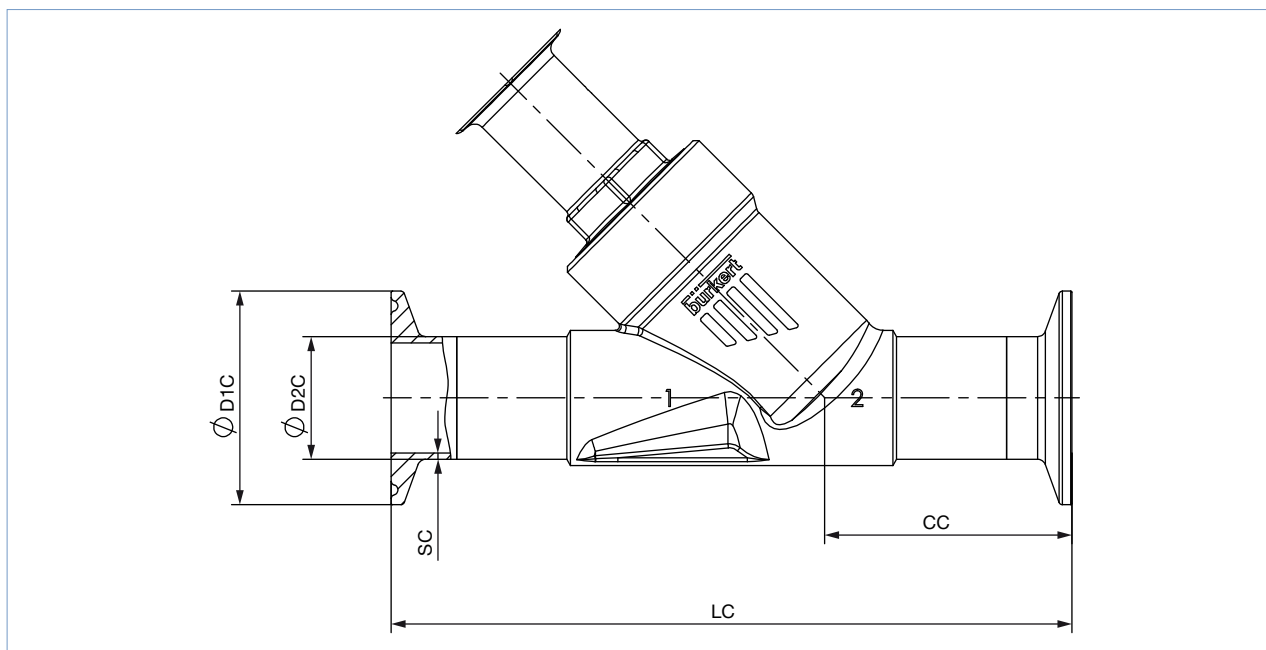

Nominal diameter (pipe)	Clamp: DIN 32676 B Pipe: EN ISO 1127 1, ISO 4200, DIN 11866 B					Clamp: DIN 32676 A (DN 15 similar DIN 32676 B) Pipe: DIN 11850 2, DIN 11866 A				
	DN	LC	CC	ØD1C	ØD2C	SC	LC	CC	ØD1C	ØD2C
15	156	49.0	50.5	21.3	1.6	130	49.5	34.0	19	1.5
20	150	56.5	50.5	26.9	1.6	150	57.0	34.0	23	1.5
25	160	58.0	50.5	33.7	2.0	160	58.5	50.5	29	1.5
32	200	57.5	50.5	42.4	2.0	180	58.0	50.5	35	1.5
40	200	69.0	64.0	48.3	2.0	200	69.5	50.5	41	1.5
50	230	77.5	77.5	60.3	2.6	230	78.0	64.0	53	1.5
65	265	77.5	91	76.1	2.0	265	78	91	70	2.0

Nominal diameter (pipe)	Clamp: ASME BPE Pipe: ASME BPE, DIN 11866 C				
	NPS	LC	CC	ØD1C	ØD2C
½	130	49.0	25.0	12.7	1.65
¾	150	56.5	25.0	19.05	1.65
1	160	58.0	50.5	25.4	1.65
1½	200	69.0	50.5	38.1	1.65
2	230	77.5	64.0	50.8	1.65
2½	286	83	77.5	63.5	1.65

DTS 1000273502 EN Version: U Status: RL (released | freigegeben | validé) printed: 28.02.2023

## 5. Performance specifications

### 5.1. Fluidic data

#### Flow characteristics

- Flow characteristic acc. to DIN EN 60534-2-4
- Modified equal percentage flow characteristic theoretical rangeability:  $K_{vS}/K_{v0}=50:1$
- $K_{vR}$  value<sup>1.)</sup> at 5 % of stroke

1.)  $K_{vR}$  value = smallest  $K_v$  value at which the inclination tolerance according to DIN EN 60534-2-4 can still be maintained.

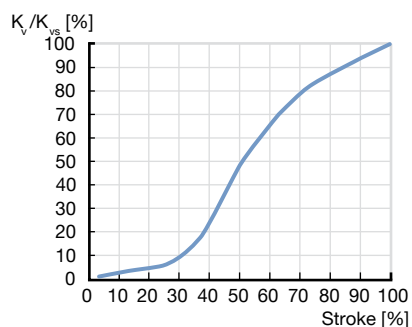

#### Overview of flow characteristics with flow below seat

##### Note:

- $K_v$  value [ $m^3/h$ ]: Measured with water acc. to DIN EN 60534-2-4
- Operating limits, see "5.2. Operating limits" on page 16

Nominal diameter (Pipe)		Actuator force <sup>1.)</sup>	Operating pressure (seat leakage class)			Characteristic curve (theoretical rangeability)	K <sub>v</sub> value at stroke						K <sub>vS</sub> value
			Valve seat seal				5 %	10 %	30 %	50 %	70 %	90 %	
DN	NPS	[N]	Stainless steel	PTFE	PEEK	[m <sup>3</sup> /h]						[m <sup>3</sup> /h]	
			[bar(g)]										
15	½ <sup>2.)</sup>	1300	25 (IV)	–	25 (VI)	Equal percentage (50:1)	0.16	0.17	0.4	2.7	4.0	4.8	5
20	¾ <sup>2.)</sup>		25 (IV)	25 (VI)	25 (VI)		0.26	0.27	1.1	5.9	8.3	9.6	10
25	1 <sup>2.)</sup>	25 (IV)	25 (VI)	20 (VI)	0.34		0.36	1.5	8.9	13.0	15.4	16	
32	1¼ <sup>2.)</sup>	1300	16 (IV)	16 (VI)	10 (VI)		0.40	0.46	2.5	13.9	19.5	23.5	25
		2500	25 (IV)	25 (VI)	20 (VI)								
40	1½ <sup>2.)</sup>	1300	10 (III)	10 (VI)	6 (VI)		0.48	0.66	5.1	20	28.5	34.5	36
		2500	18 (IV)	18 (VI)	14 (VI)								
		7700	25 (IV)	–	25 (VI)								
50	2 <sup>2.)</sup>	1300	6 (III)	6 (VI)	–	0.87	1.2	4	26	40.5	48	53	
		2500	10 (III)	10 (VI)	8 (VI)								
		7700	25 (IV)	–	25 (VI)								
65	2½ <sup>2.)</sup>	10000	25 (IV)	–	25 (VI)	1.7	2	20	48	67	83	90	

1.) AG2: Actuator size 2 with a nominal force of 1300 or 2500 N

AG3: Actuator size 3 with a nominal force of 7700 or 10000 N

2.) Deviation for line connections according to ASME BPE: the next larger nominal connection size is used, e.g. NPS 1 instead of NPS ¾

## 5.2. Operating limits

### Operating limits for medium temperature and operating pressure

The operating range of Bürkert process valves is in addition to the maximum operating pressures limited by the nominal pressure according to the relevant standard.

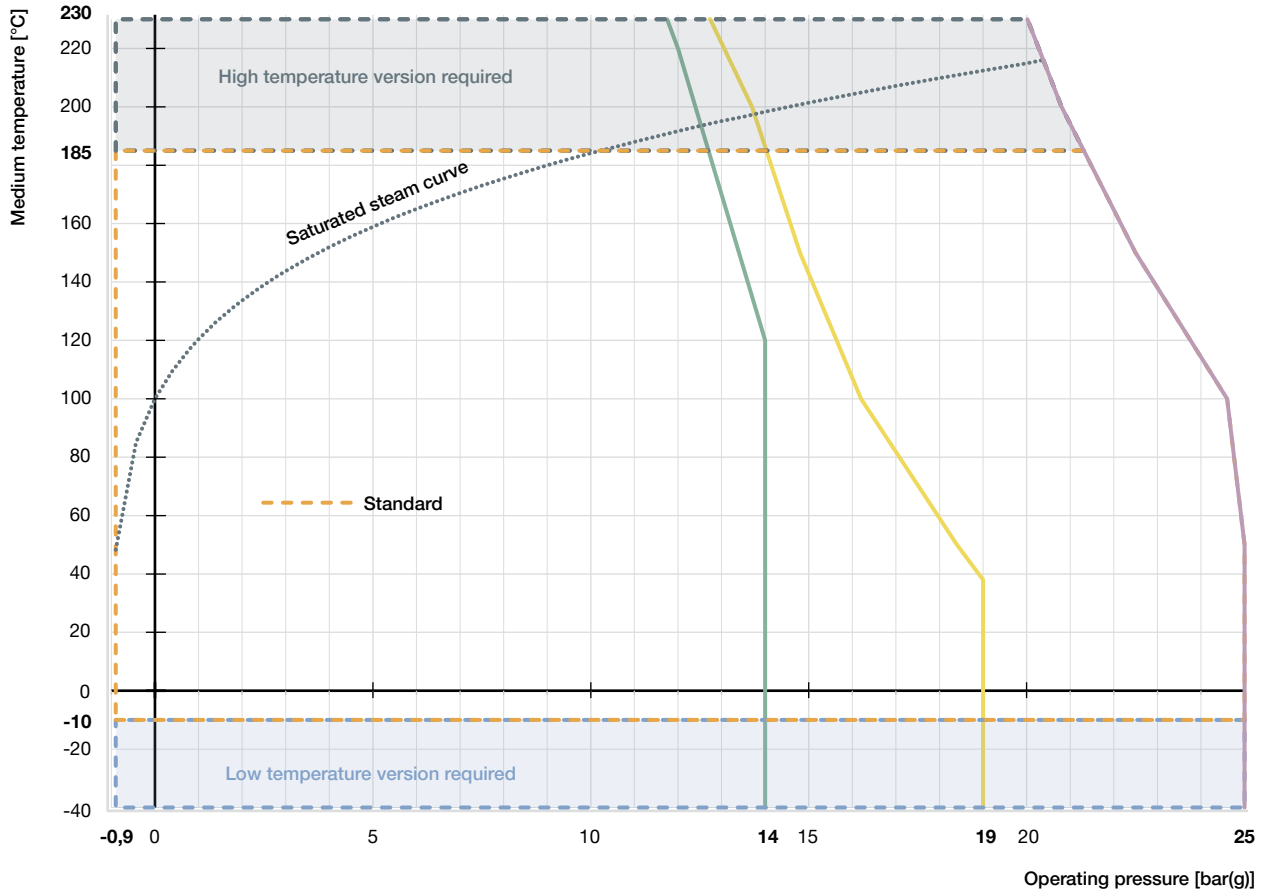

- Operating limits for PN25 acc. to DIN EN 12516-1
- Operating limits for flange 10K acc. to JIS B 2220
- Operating limits for Class 150 acc. to ASME B16.34
- ⋯ Saturated steam curve for water



**Operating limits for ambient and medium temperature**

The maximum permissible temperature for the environment and the medium are dependent on each other. The maximum allowable temperature curves of different device variants can be seen in the temperature chart. The curves were determined for maximum operating conditions (max. operating pressure and motor power). For deviating operating conditions an individual verification can be performed. Please contact your Bürkert office for more information.

**AG2**

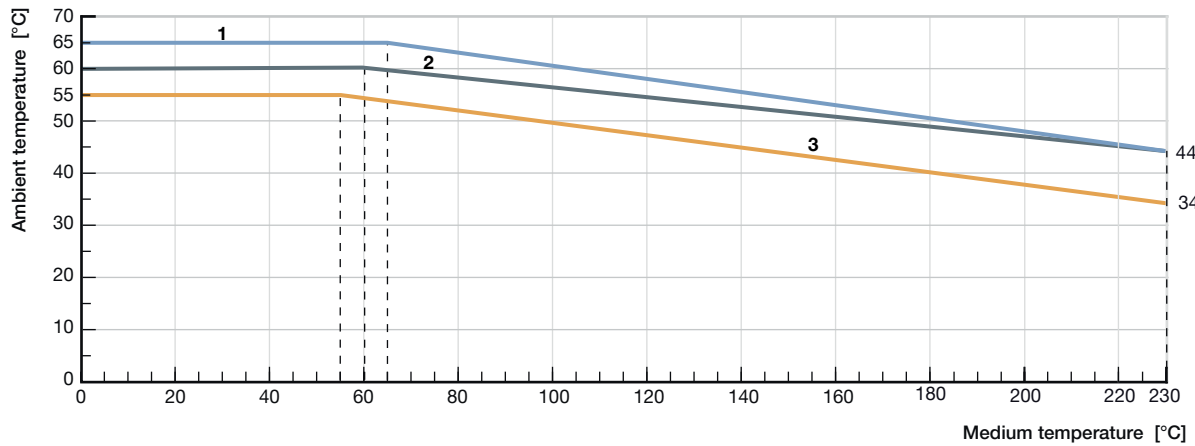

No.	Description
1	Devices without module
2	Devices with display
3	Devices with SAFEPOS energy-pack or fieldbus gateway, with/without display module

**AG3**

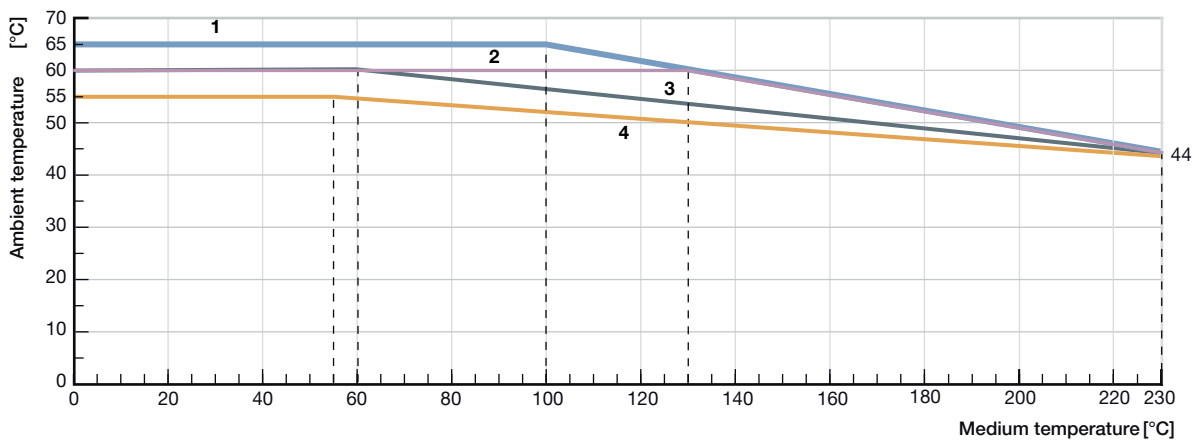

No.	Description
1	Devices without module
2	Devices with SAFEPOS energy-pack
3	Devices with display module with/without SAFEPOS energy-pack
4	Devices with fieldbus gateway with/without display module with/without SAFEPOS energy-pack

DTS 1000273502 EN Version: U Status: RL (released | freigegeben | valide) printed: 28.02.2023

## Operating limits for seat seal

Tight sealing required	Leakage class (DIN EN 60534 - 4)	Medium temperature	Seat seal
No An additional shut-off valve is recommended	III/IV (metal seals)  Metal-sealed valves have larger leakages (0.1 % or 0.01 % of the nominal flow rate are permissible).  Metallic seals are impervious even under demanding process conditions.	-40...230 °C	Stainless steel
Yes An additional shut-off valve is often unnecessary.	VI (soft seals)  By using plastics as sealing material, the control valves can close tightly.  Their use is not recommended in cases of increased erosion due to demanding process conditions.	-40...130 °C (recommended for ≤ 130 °C)	PTFE
		-10...230 °C (recommended for > 130 °C)	PEEK

## Operating limits for optional versions

**High temperature version**

By adapting the spindle sealing this version is suitable for applications with steam, neutral gases and other heat transfer mediums up to 230 °C.

**Drinking water version**

Materials in contact with the medium are tested for suitability with drinking water up to 85 °C.

**Vacuum version**

Without leakage bore, this design is suitable for pressures down to -0.9 bar(g).

**Low temperature version**

Suitable for minimum medium temperatures down to -40 °C

**Version for oxygen**

Non-metallic materials in contact with the medium are tested for suitability with oxygen. Suitable for operating pressures up to 25 bar(g) and medium temperatures up to 60 °C.

### 5.3. Electrical control and interfaces

#### Interface diagram

The position of the actuator is controlled according to the position setpoint. The position setpoint is given either by an external standard signal (analogue) or via a fieldbus (digital).

#### Analogue control

For the analogue control 2 variants each are available for the inputs and outputs and the connection interface.

#### Inputs and outputs:

- 1 analogue input, 1 digital input
- 1 analogue input, 1 digital input, 1 analogue output, 2 digital output (optional)
- 1 analogue input process actual value (for optional version with process controller)

#### Interface:

- Cable gland with connection terminal (only AG2)
- M12 circular plug-in connectors (optional)

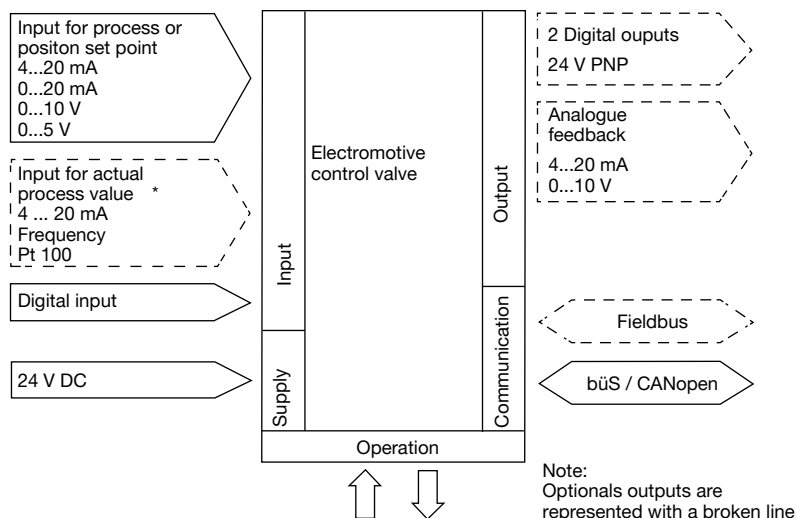

#### Control data

Analogue setpoint input	Galvanically isolated from supply voltage and analogue output 0/4...20 mA (input resistance < 70 Ω) 0...5/10 V (input resistance 22 kΩ)
Analogue output	Max. current 10 mA (for voltage output 0...5/10 V) Burden (load) 0...800 Ω (for current output 0/4...20 mA)
Digital input	0...5 V = log "0", 10...30 V = log "1" inverted input reversed accordingly
Digital output	PNP, Current limitation 100 mA

#### Analogue actual value signal input (optional)

4...20 mA	Input resistance: < 70 Ω Resolution: 12 Bit
Frequency	Measuring range: up to 1000 Hz Input resistance: > 30 kΩ Resolution: 0.1 % of measured value Input signal: > 300 mV <sub>ss</sub> Signal shape: sine, rectangle, triangle
Pt 100	Measuring range: -20 °C...+220 °C Resolution: 0.01 °C Measuring current: 1 mA

#### Communication

Communication interface (bÜS)	Connection to PC via USB bÜS interface set
Communication software (bÜS)	Bürkert Communicator, see <b>Type 8920</b> ▶

## 6. Product design and assembly



### 6.1. Product features

**Note**

More detailed information can be found in the **operating instructions** ►.

User interface	
<p><b>Device without display module:</b> In the version without operating display, the basic functions are operated via 4 DIP switches and 2 push buttons. These are located under the blind cover, which can be removed by turning it manually. The device can also be configured in detail with the Bürkert Communicator software via the bÜS service interface. The buttons and switches are inactive for version with optional display module</p>	<p style="text-align: right;"><b>Blind cover dismantled</b></p>
<p><b>Rugged Touch Display (optional):</b> The robust display module offers convenient operation, configuration and display of all necessary functions. Besides the start screen, various views can be freely configured. The bÜS service interface is also available here under the display module. The display cannot be retrofitted in the field..</p>	
Actuation	
<p><b>Mechanical manual control:</b> The manual override for mechanical movement of the valve is located for AG2 under the blind cover or display module and for AG3 under the pressure compensation element. It ensures that the actuator can be operated even if the power supply fails.</p>	
<p><b>Electrical control via operating elements:</b> The electrical manual override for operation can be carried out directly on the touch display or, in the version without display, via two buttons under the blind cover.</p>	
Display elements	
<p><b>Display</b> 360° LED light ring: A clearly visible 360° LED ring is attached to the blind cover or display module to indicate the device status, the valve end position and the operating status. The LED light ring lights up, blinks or flashes into one or changing colours, depending on the LED mode set</p>	
<p><b>Mechanical position indicator:</b> The mechanical position indicator shows the current valve position even if the supply voltage fails.</p>	
Data transmission (optional)	
<p><b>SIM card (optional):</b> With the optionally available SIM card, device-specific values and user settings can be stored and quickly transferred to another device.</p>	

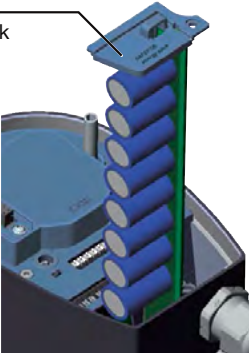
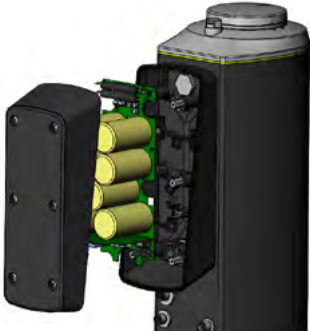
DTS 1000273502 EN Version: U Status: RL (released | freigegeben | validé) printed: 28.02.2023

Safety position via energy storage (optional)	AG2	AG3
<p>The safety starting positions in case of power interruption is realized with the optional energy storage SAFEPOS energy-pack. The desired position is set via the menu. In addition to the end positions (open/closed), any desired intermediate position can be defined here. The energy storage has a lifespan of up to 10 years, depending on the operating conditions. The power of the energy storage is monitored and a warning is displayed to indicate its life is coming to an end. The storage device is designed as a plug-in module to facilitate replacement. Without energy storage, the valve remains in the last position it was in. The energy storage device is fully charged and ready for operation after a maximum of 120 seconds (depending on the operating conditions). The energy storage device cannot be retrofitted in the field.</p>	 <p>SAFEPOS energy-pack</p>	
Fieldbus: EtherNet/IP, PROFINET, Modbus TCP (optional)		
<p>The fieldbus gateway for EtherNet/IP, PROFINET and Modbus TCP is integrated in an additional module. It has 2 fieldbus connections with 4 pin M12 circular sockets. The interfaces for the fieldbus connection and the status LEDs are located under the gateway housing cover. If there is a need for it to be include in a network then the configuration of the Ethernet can be performed via the web server. The gateway cannot be retrofitted in the field.</p>	 <p>Display module</p> <p>Fieldbus gateway</p> <p>Fieldbus M12 connection (2 Port Ethernet Switch)</p>	

DTS 1000273502 EN Version: U Status: RL (released | freigegeben | valide) printed: 28.02.2023

### 6.2. Product assembly

The electromotive linear drive consists of a brushless DC motor, a gear and a spindle system that transfers the force to the control cone. The integrated control electronics are controlled either via standard signals (analogue) or via a field bus (digital). A positioner and a process controller are available as controller versions. The electromotive linear actuator is designed to provide optimum efficiency. At the same time, it keeps the valve tight and in position even at the maximum specified medium pressure in a powerless standstill. An optional energy storage device (SAFEPOS energy-pack) is available for the device. If the supply voltage fails, it supplies the actuator with the energy required to move the valve into the desired position, which can be set in the menu.

The valve position can be changed manually in 2 ways. Either via the electrical manual control or via a mechanical manual control if no supply voltage is available. The device can be set and operated either via 2 capacitive keys and 4 DIP switches or optionally on a display with touch screen. In addition there is always the possibility to operate the device via the bÜS service interface and using the "Bürkert Communicator" software.

The intelligent process valve Type 3360 offers the operator options for process monitoring, valve diagnosis and preventive maintenance. Internal measurements of the operating status are evaluated and, if necessary, issued as a warning or error message. These signal, for example, impermissible ambient and process conditions, functional deviations of components or the status of the energy storage device

#### AG2

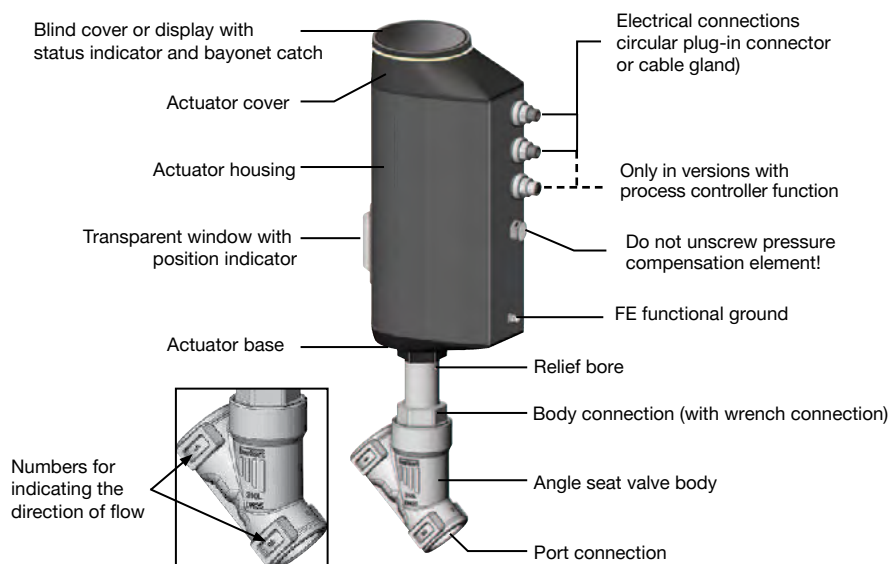

DTS 1000273502 EN Version: U Status: RL (released | freigegeben | valide) printed: 28.02.2023

AG3

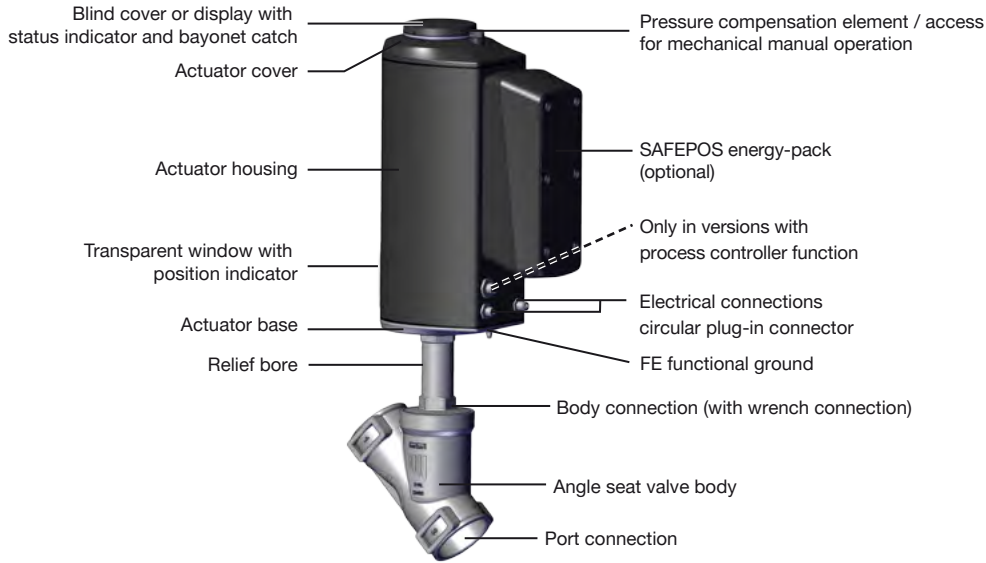

**Integrated position controller**

The position of the actuator (stroke) is controlled according to the position setpoint. The position setpoint is either given by an external standard signal (analogue) or via a fieldbus (digital). The displacement transducer records the actual position (POS) of the electric linear actuator. This actual position value is compared by the positioner with the position setpoint (CMD) specified as standard signal. If there is a system deviation ( $X_{d1}$ ), the electric motor drive is controlled via the manipulated variable CTRL and the actual position value is changed accordingly.

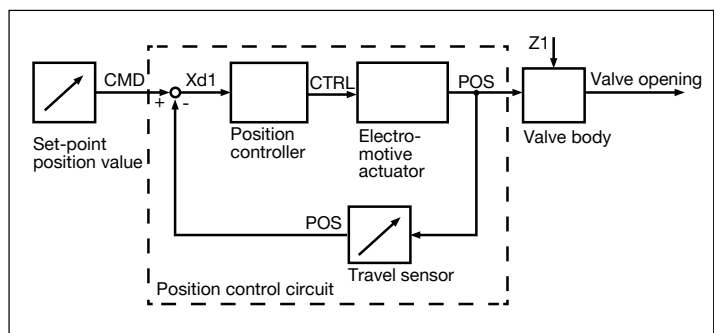

**Integrated process controller (optional)**

The additionally implemented PID controller allows process control. The setpoint position of the valve is calculated from the external signal (e.g. level, pressure, flow rate, temperature) for the process setpoint and the actual process value via the control parameters (PID controller).

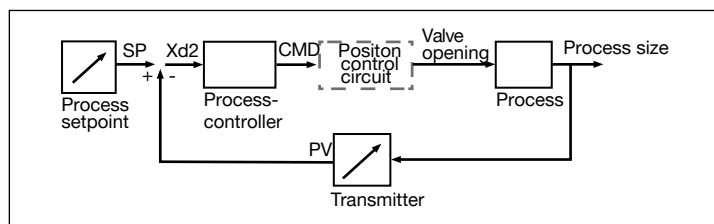

DTS 1000273502 EN Version: U Status: RL (released | freigegeben | valide) printed: 28.02.2023

## 7. Ordering information

### 7.1. Bürkert eShop – Easy ordering and quick delivery



#### Bürkert eShop – Easy ordering and fast delivery

You want to find your desired Bürkert product or spare part quickly and order directly? Our online shop is available for you 24/7. Sign up and enjoy all the benefits.

[Order online now](#)

### 7.2. Bürkert product filter









#### Bürkert product filter – Get quickly to the right product

You want to select products comfortably based on your technical requirements? Use the Bürkert product filter and find suitable articles for your application quickly and easily.

[Try out our product filter](#)

### 7.3. Ordering chart accessories





#### Standard accessories

Description	Article no.
SIM card for data transmission between devices	291773 
Holding device for port connection DN 15...20	693770 
Holding device for port connection DN 25...50	693771 
Plastic blind cover	277881 
Energy storage SAFEPOS energy-pack (AG2)	285834 
Energy storage SAFEPOS energy-pack (AG3)	20046438 

#### Accessories cable

##### Note:

For connection to a bus/CANopen network see [cabling guide](#) ►.



Description	Article no.
Connection cable with M12 socket, 4 pin, (length 5 m) for operating voltage (without communication)	918038 
Connection cable with M12 socket, 5 pin, L coded (length 5 m) for operating voltage AG3 (without communication)	20010840 
Connection cable with M12 socket, 8 pin, (length 2 m) for input and output signals	919061 
Connection cable with M12 plug, 5 pin, (length 2 m) for input of process actual value signals (only for version with process controller)	559177 



### Bürkert accessories

#### Note:

- For connection to a bus/CANopen network see **cabling guide** ▶.
- Detailed accessory tables can be found in the cabling guide

Description	Article no.
Software Bürkert Communicator, Type 8920	<b>LINK</b> ▶
büS stick set 1 (including power supply unit, bus-stick, terminating resistor, Y-distributor, 0.7 m cable with M12 connector)	772426 
büS stick set 2 (including bus-stick, terminating resistor, Y-distributor, 0.7 m cable with M12 connector)	772551 
büS adapter for büS interface set (M12 on büS service interface Micro-USB)	773254 

### 7.4. Bürkert product enquiry form

**Bürkert product enquiry form:** Would you like to make a specific product enquiry based on your technical requirements? Please use our product enquiry form **at the end of this data sheet**. There you will find all the information relevant to your Bürkert contact person that will help us to process your enquiry in the best possible way.

**Bürkert specification key:** In our product enquiry form you will find a complete explanation of the composition of our specification key. You will find our product enquiry form **at the end of this data sheet**.

# Bürkert – Close to You

For up-to-date addresses  
please visit us at  
[www.burkert.com](http://www.burkert.com)

DTS 1000273502 EN Version: U Status: RL (released | freigegeben | validé) printed: 28.02.2023



## Product Enquiry Form - Electromotive Control Valves

Thank you for your interest in our products! In order to provide you with optimum advice, please fill out the following form and send it to your **Bürkert representative** or e-mail address: [info@burkert.com](mailto:info@burkert.com). All information submitted will of course be kept strictly confidential.

Please fill in the **required fields!**  \*

\*Note: The interactive functions of this PDF may be restricted depending on the PDF reader used.

Personal Information			
Company		Contact person	
Customer no.		Department	
Street		Postcode / Town	
Telephone no.		Email	

Delivery	
Quantity	Required delivery date

Operating data	
Function <small>(Function of the control valve in the process / process description)</small>	
Pipeline	DN PN
Operating medium	
Type of medium	Fluid Steam Gas

Fluidic data	Largest flow rate 1. Operating point	Average flow rate 2. Operating point	Lowest flow rate 3. Operating point	Unit
Flow rate				
Temperature $t_1$				
Inlet pressure $p_1$ <small>absolute (a) relative (g)</small>				
Outlet pressure $p_2$ <small>absolute (a) relative (g)</small>				
Steam pressure $p_v$				
Viscosity ( $\nu / \eta$ )				
Density ( $\rho$ )				
Max. permitted sonic pressure level ( $L_p$ )				

Valve body				
Construction	Angle seat valve		Globe valve	
DN / Nominal pressure	DN		PN	
Seat size				
Flow coefficient	$K_{vs}$	$m^3/h$	$C_v$	GPM(US)
Seat seal	metallic		soft seal PTFE soft seal PEEK	
Connection	Flange	DIN EN 1092-1		ANSI B16.5 JIS 10K
	Thread	G		NPT RC
	Weld	DIN EN ISO 1127 / ISO 4200		DIN 11850 2 / DIN 11866 A ASME BPE
	Clamp	ASME BPE		DIN 32676 A (tube ISO 4200) DIN 32676 B (tube DIN 11850)
	Other			

Valve data	
<b>Safety position</b>	With energy storage (factory setting NO) With energy storage (factory setting NC) Without energy storage (last valve position blocked)
<b>Function</b>	Positioner                      Process controller
<b>Operation</b>	With Touch-Display              Without Touch-Display, internal button
<b>Electrical connection</b>	Cable gland                      M12 multi-pin plug connection
<b>Communication</b>	<b>Analogue:</b> 1 AI, 1 DI                      1 AI, 1 DI, 1 AO, 2 DO <b>Digital (Fieldbus):</b> EtherNet/IP                  PROFINET                  Modbus TCP CANopen                      büS
<b>SIM card</b>	With                      without

Approvals / Conformities
For use with food (conform to EG regulation no. 1935/2004)
For use with food (conform to FDA)
Explosion protection in accordance with ATEX II 3GD / IECex
cULus
Suitable for drinking water <sup>1.)</sup>
Certificate for the fulfilment of the order EN-ISO 10204 2.1 (Article no. 815417)
Test report EN-ISO 10204 2.2 (Article no. 803722)
Conformity certification for raw material EN-ISO 10204 3.1 (Article no. 803723)

1.) For use with drinking water for medium temperatures up to 85 °C in accordance with the Drinking Water Ordinance §17 and the assessment principles of the Federal Environment Agency.

Additional Requirements / Comment