



### Inline flowmeter with paddle wheel, ELEMENT design

- Size of measurement pipes: DN 06 to DN 65
- Configurable outputs: one or two transistor output(s) and one or two 4...20 mA current output(s)
- Removable backlit display/configuration module for indication of flow rate and volume with two flow totalizers
- Automatic calibration using Teach-In, all outputs can be checked without the need for actual flow



Product variants described in the data sheet may differ from the product presentation and description.

#### Can be combined with

- 

**Type 8611** ▶  
eCONTROL - Universal controller
- 

**Type 2030** ▶  
Pneumatically operated 2/2 way diaphragm valve CLASSIC with plastic body
- 

**Type 2101** ▶  
Pneumatically operated 2/2-way globe valve ELEMENT for decentralised automation
- 

**Type 8692** ▶  
Digital electropneumatic Positioner for the integrated mounting on process control valves
- 

**Type 8644** ▶  
Remote Process Actuation Control System AirLINE
- 

**Type 8619** ▶  
multiCELL - Multi-channel and multi-function transmitter/controller

#### Type description

The flowmeter Type 8036 is a compact device, specially designed for measuring the flow rate in solid-free liquids, in a variety of applications (water, waste water monitoring, chemical processing, etc.).

Type 8036 is available with:

- 2 configurable outputs: one transistor output (NPN) and one 4...20 mA current output (2-wire)
- 3 configurable outputs: two transistor outputs (NPN/PNP) and one 4...20 mA current output (2-wire)
- 4 configurable outputs: two transistor outputs (NPN/PNP) and two 4...20 mA current outputs (3-wire).

Type 8036 converts the measured signal, displays different values in different units (if display/configuration module mounted) and computes the output signals, which are provided via one or two M12 fixed connectors. Thanks to 1 or 2 transistor outputs, the flowmeter can be used to switch a solenoid valve, activate an alarm and, thanks to 1 or 2 current outputs, establish one or two control loops.

## Table of contents

|  |           |
|--|-----------|
| <b>1. General technical data</b>                                 | <b>3</b>  |
| <b>2. Approvals</b>  | <b>5</b>  |
| 2.1. Certification UL.....                                       | 5         |
| 2.2. Pressure Equipment Directive.....                           | 5         |
| Device used on a pipe.....                                       | 5         |
| <b>3. Materials</b>  | <b>5</b>  |
| 3.1. Chemical Resistance Chart – Bürkert resistApp.....          | 5         |
| 3.2. Material specifications.....                                | 6         |
| <b>4. Dimensions</b>   | <b>6</b>  |
| 4.1. Transmitter SE36.....                                       | 6         |
| 4.2. Transmitter SE36 mounted in a S030 sensor-fitting.....      | 7         |
| <b>5. Performance specifications</b>                             | <b>7</b>  |
| 5.1. Pressure temperature diagram.....                           | 7         |
| <b>6. Product installation</b>                                   | <b>8</b>  |
| 6.1. Installation notes.....                                     | 8         |
| <b>7. Product operation</b>                                      | <b>8</b>  |
| 7.1. Measuring principle.....                                    | 8         |
| <b>8. Product design and assembly</b>                            | <b>9</b>  |
| 8.1. Product assembly.....                                       | 9         |
| <b>9. Networking and combination with other Bürkert products</b> | <b>9</b>  |
| <b>10. Ordering information</b>                                  | <b>10</b> |
| 10.1. Bürkert eShop – Easy ordering and quick delivery.....      | 10        |
| 10.2. Recommendation regarding product selection.....            | 10        |
| 10.3. Bürkert product filter.....                                | 10        |
| 10.4. Ordering chart for flow transmitter Type SE36.....         | 11        |
| 10.5. Ordering chart accessories.....                            | 11        |

## 1. General technical data

### Note:

If the device is mounted in a humid environment or outside, then the maximum voltage allowed is **35 V DC** instead of 36 V DC.

### Product properties

#### Material

Please make sure the device materials are compatible with the fluid you are using.

Detailed information can be found in chapter **"3.1. Chemical Resistance Chart – Bürkert resistApp"** on page 5.

#### Non wetted parts

|                              |   |
|------------------------------|---|
| Housing                      | Stainless steel 1.4404 (316L), PPS                  |
| Cover                        | Polycarbonate (PC), transparent (opaque on request) |
| Display/configuration module | PC  |
| Navigation key               | PBT   |
| Seals                        | EPDM, silicone                                      |
| Screws                       | Stainless steel 1.4401 (316 (A4))                   |
| Fixed connector holder       | PPS CF30  |
| Fixed connector              | Nickel-plated brass (stainless steel on request)    |
| Grounding terminal and screw | Stainless steel 1.4301 (304 (A2))                   |
| Quarter turn system          | PC  |

#### Wetted parts

|                                      |   |
|--------------------------------------|---|
| Sensor-fitting body, sensor armature | Brass, stainless steel, PVC, PP or PVDF (depending on S030 version) |
| Seal                                 | FKM or EPDM (depending on S030 version)                             |
| Axis and bearings                    | Ceramics (Al <sub>2</sub> O <sub>3</sub> )                          |
| Paddle wheel                         | PVDF  |

Dimensions Detailed information can be found in chapter **"4. Dimensions"** on page 6

Measuring principle Paddle wheel

Compatibility Any pipe from DN 06...DN 65 which is fitted with Bürkert S030 Inline sensor-fitting. For the selection of the nominal diameter of the Inline sensor-fittings, see **data sheet Type S030** ▶.

Pipe diameter DN 06...DN 65

Measuring range

- Flow rate: 0.5...1200 l/min (0.13...320 gpm)
- Flow velocity: 0.3...10 m/s

#### Product accessories

Display/configuration module Grey dot matrix 128 x 64 with backlighting

#### Performance data

Measurement deviation Teach-In: ±1 % of the measured value<sup>1)</sup> (at Teach-In flow rate value)  
Standard K-factor: ±2.5 % of the measured value<sup>1)</sup>

Linearity ±0.5 % of full scale<sup>1)</sup>

Repeatability ±0.4 % of the measured value<sup>1)</sup>

4...20 mA output uncertainty ±1 % of range

#### Electrical data

Operating voltage

- 2 or 3 outputs transmitter (2-wire) version: 14...36 V DC, filtered and regulated
- 4 outputs transmitter (3-wire) version: 12...36 V DC, filtered and regulated

Connection to main supply: permanent (through external SELV (Safety Extra Low Voltage) and LPS (Limited Power Source) power supply

Power source (not supplied) Limited power source according to UL/EN 60950-1 standards or limited energy circuit according to UL/EN 61010-1 §9.4

DC reverse polarity protection Yes

Overvoltage protection Yes

Current consumption

With sensor

- ≤1 A (with transistors load)
- 2 or 3 outputs transmitter (2-wire) version: ≤25 mA (at 14 V DC without transistors load, with current loop)
- 4 outputs transmitter (3-wire) version: ≤5 mA (at 12 V DC without transistors load, without current loop)

Power consumption Max. 40 W

**Outputs**

|                      |  |
|----------------------|--|
| Transistor           | Protected against overvoltage, polarity reversals and short circuit <ul style="list-style-type: none"> <li>• 1 transistor output (transmitter 2-wire): <ul style="list-style-type: none"> <li>– NPN, open collector</li> <li>– 1...36 V DC</li> <li>– Max. 700 mA</li> </ul> </li> <li>• 2 transistor outputs (transmitter 2 or 3-wire): <ul style="list-style-type: none"> <li>– Adjustable as sourcing or sinking (respectively both as PNP or NPN ), open collector</li> <li>– Max. 700 mA</li> <li>– 0.5 A max. per transistor if the 2 transistor outputs are wired</li> <li>– NPN-output: 1...36 V DC</li> <li>– PNP-output: Power supply</li> </ul> </li> </ul> |
| Current              | 4...20 mA adjustable as sourcing or sinking (in the same mode as transistor): <ul style="list-style-type: none"> <li>• 1 current output (transmitter 2-wire)<br/>Max. loop impedance: 1100 Ω at 36 V DC; 610 Ω at 24 V DC; 180 Ω at 14 V DC</li> <li>• 2 current outputs (transmitter 3-wire)<br/>Max. loop impedance: 1100 Ω at 36 V DC; 610 Ω at 24 V DC; 100 Ω at 12 V DC</li> </ul>  |
| Voltage supply cable | For the female M12 connector and/or the male M12 connector (not supplied, to order separately, see chapter <b>“10.5. Ordering chart accessories” on page 11</b> ) use a shielded cable. <ul style="list-style-type: none"> <li>• Ø 3...6.5 mm</li> <li>• Cross section of wires: max. 0.75 mm<sup>2</sup></li> </ul>   |

**Medium data**

|                         |  |
|-------------------------|--|
| Fluid temperature       | With sensor-fitting S030 in: <ul style="list-style-type: none"> <li>• PVC: 0...+50 °C (+32...+122 °F)</li> <li>• PP: 0...+80 °C (+32...+176 °F)</li> <li>• PVDF, stainless steel or brass: -15...+100 °C (+5...+212 °F)</li> </ul> See <b>data sheet Type S030</b> ▶ for more information. |
| Fluid pressure (max.)   | With sensor-fitting S030 in: <ul style="list-style-type: none"> <li>• plastic: PN 10</li> <li>• metal: PN 16 (PN 40 on request)</li> </ul> See <b>data sheet Type S030</b> ▶ for more information.   |
| Viscosity               | Max. 300 cSt   |
| Rate of solid particles | Max. 1 %   |
| Maximum particle size   | 0.5 mm   |

**Process/Port connection & communication**

|                       |   |
|-----------------------|---|
| Process connection    | With sensor-fitting S030 in: <ul style="list-style-type: none"> <li>• plastic: true union, spigot or external thread</li> <li>• metal: internal or external thread, weld ends, Clamp or flange</li> </ul> See <b>data sheet Type S030</b> ▶ for more information. |
| Electrical connection | <ul style="list-style-type: none"> <li>• 2 or 3 outputs transmitter (2-wire) version: 1 x 5 pin M12 male fixed connector</li> <li>• 4 outputs transmitter (3-wire) version: 1 x 5 pin M12 male and 1 x 5 pin M12 female fixed connectors</li> </ul>               |

**Approvals and Certificates****Standards**

|                                    |  |
|------------------------------------|--|
| Degree of protection <sup>2)</sup> | IP65, IP67 (according to IEC/EN 60529), NEMA 4X (according to NEMA250) with device wired and M12 cable plug mounted and tightened and cover fully screwed down |
|------------------------------------|--|

**Directives**

|                               |  |
|-------------------------------|--|
| CE directives                 | The applied standards, which verify conformity with the EU Directives, can be found on the EU Type Examination Certificate and/or the EU Declaration of conformity (if applicable)                                       |
| Pressure equipment directives | Complying with Article 4, Paragraph 1 of 2014/68/EU directive<br>Detailed information on the pressure equipment directive can be found in chapter <b>“3.1. Chemical Resistance Chart – Bürkert resistApp” on page 5.</b> |
| Certification                 | UL-Recognized for US and Canada  |

| Environment and installation |   |
|------------------------------|---|
| Ambient temperature          | Operation and storage: - 10...+60 °C (+ 14...+ 140 °F)  |
| Relative air humidity        | ≤ 85 %, without condensation  |
| Height above sea level       | Max. 2000 m   |
| Operating condition          | Continuous  |
| Equipment mobility           | Fixed   |
| Application range            | Indoor and outdoor (protect the device against electromagnetic interference, ultraviolet rays and against the effects of climatic conditions) |
| Installation category        | Category I according to UL/EN 61010-1   |
| Pollution degree             | Degree 2 according to UL/EN 61010-1   |

- 1.) Under reference conditions i.e. measuring fluid = water, ambient and water temperature = 20 °C (68 °F), while maintaining the minimum inlet and outlet distances and the appropriate internal diameters of the pipes.
- 2.) Not evaluated by UL

## 2. Approvals

### 2.1. Certification UL

| Certificate | Description   |
|-------------|---|
|             | <p><b>UL-Recognized for USA and Canada</b><br/>                     Products are UL-certified products and comply also with the following standards:</p> <ul style="list-style-type: none"> <li>• UL 61010-1</li> <li>• CAN/CSA-C22.2 No.61010-1</li> </ul> |

### 2.2. Pressure Equipment Directive

The device conforms to Article 4, Paragraph 1 of the Pressure Equipment Directive 2014/68/EU under the following conditions:

#### Device used on a pipe

**Note:**

- The data in the table is independent of the chemical compatibility of the material and the fluid.
- PS = maximum admissible pressure; DN = nominal diameter of the pipe

| Type of fluid                              | Conditions                          |
|--|-------------------------------------|
| Fluid group 1, Article 4, Paragraph 1.c.i  | DN ≤ 25                             |
| Fluid group 2, Article 4, Paragraph 1.c.i  | DN ≤ 32 or PS*DN ≤ 1000             |
| Fluid group 1, Article 4, Paragraph 1.c.ii | DN ≤ 25 or PS*DN ≤ 2000             |
| Fluid group 2, Article 4, Paragraph 1.c.ii | DN ≤ 200 or PS ≤ 10 or PS*DN ≤ 5000 |

## 3. Materials

### 3.1. Chemical Resistance Chart – Bürkert resistApp

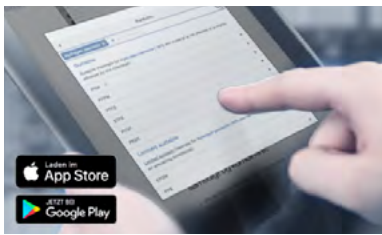

**Bürkert resistApp – Chemical Resistance Chart**

You want to ensure the reliability and durability of the materials in your individual application case? Verify your combination of media and materials on our website or in our resistApp.

Start Chemical Resistance Check

### 3.2. Material specifications

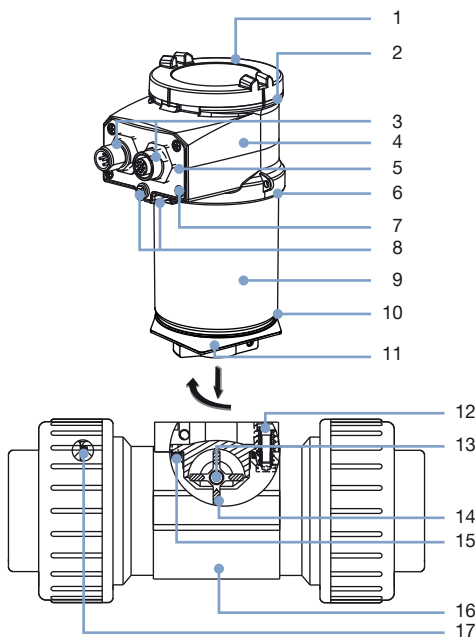

| No. | Element                            | Material   |
|-----|------------------------------------|--|
| 1   | Cover                              | PC   |
| 2   | Seal                               | Silicone   |
| 3   | Fixed connector (female /male M12) | Nickel-plated brass  |
| 4   | Housing (top)                      | PPS  |
| 5   | Fixed connector holder             | PPS CF30   |
| 6   | Seal                               | EPDM   |
| 7   | Screws                             | Stainless steel 1.4301 (304 (A2))  |
| 8   | Grounding terminal and screw       | Stainless steel 1.4401 (316 (A4))  |
| 9   | Housing (body)                     | Stainless steel 1.4404 (316L)  |
| 10  | Seal                               | EPDM   |
| 11  | Housing (base)                     | PPS  |
| 12  | Screws                             | Stainless steel 1.4301 (304 (A2))  |
| 13  | Axis and bearings                  | Ceramics (Al <sub>2</sub> O <sub>3</sub> )   |
| 14  | Paddle wheel                       | PVDF   |
| 15  | Seal                               | FKM or EPDM (depending on the sensor-fitting version S030)   |
| 16  | Sensor-fitting body                | Stainless steel 1.4404 (316L), brass, PVC, PP, PVDF (depending on S030 version)                                |
| 17  | Seals                              | FKM or EPDM (depending on S030 version and only for true union connection with nut and solvent/ fusion socket) |

## 4. Dimensions

### 4.1. Transmitter SE36

**Note:**

Specifications in mm

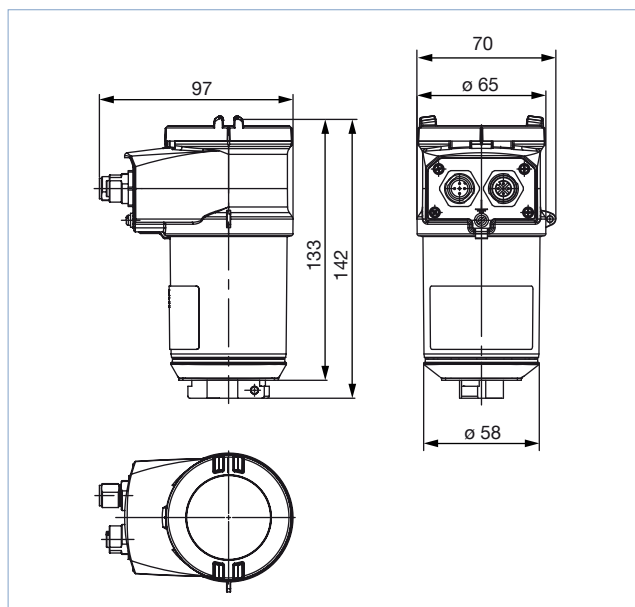

### 4.2. Transmitter SE36 mounted in a S030 sensor-fitting

**Note:**  
Specifications in mm

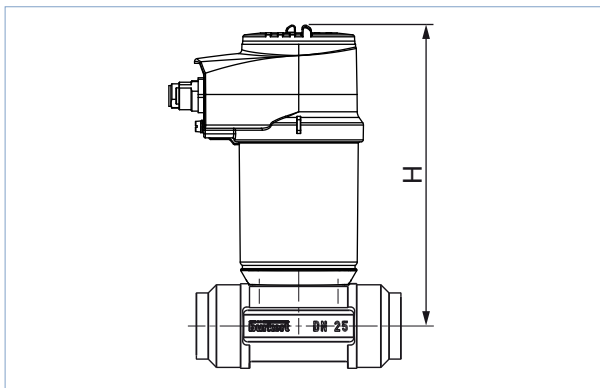

| DN | H   |
|----|-----|
| 06 | 162 |
| 08 | 162 |
| 15 | 167 |
| 20 | 165 |
| 25 | 165 |
| 32 | 168 |
| 40 | 172 |
| 50 | 179 |
| 65 | 179 |

## 5. Performance specifications

### 5.1. Pressure temperature diagram

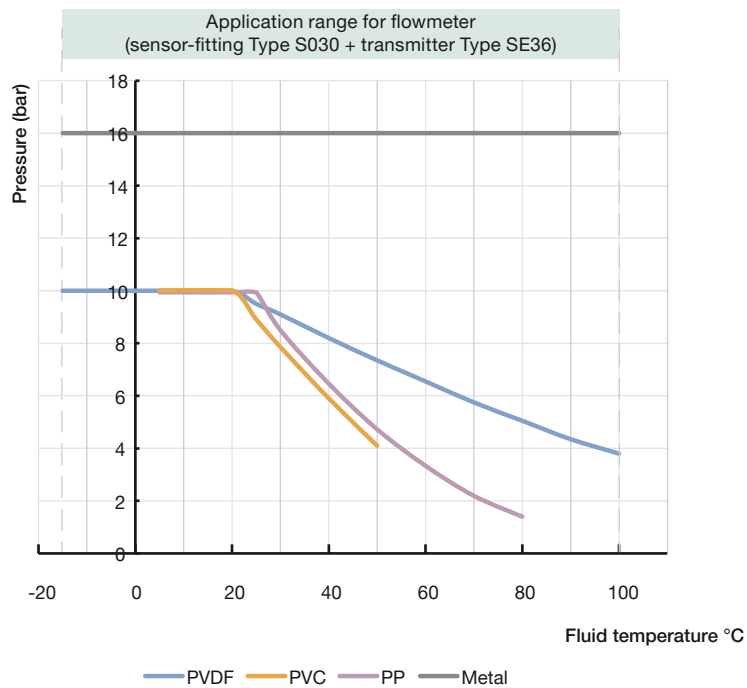

## 6. Product installation

### 6.1. Installation notes

**Note:**

The device is not designed for gas and steam flow measurement.

Minimum straight upstream and downstream distances must be observed. According to the pipe's design, necessary distances can be bigger or use a flow conditioner to obtain the best accuracy.

For more information, please refer to EN ISO 5167-1.

EN ISO 5167-1 prescribes the straight inlet and outlet distances that must be complied with when installing fittings in pipe lines in order to achieve calm flow conditions. The most important layouts that could lead to turbulence in the flow are shown below, together with the associated prescribed minimum inlet and outlet distances.

Make sure that the measuring conditions at the point of measurement are calm and problem-free.

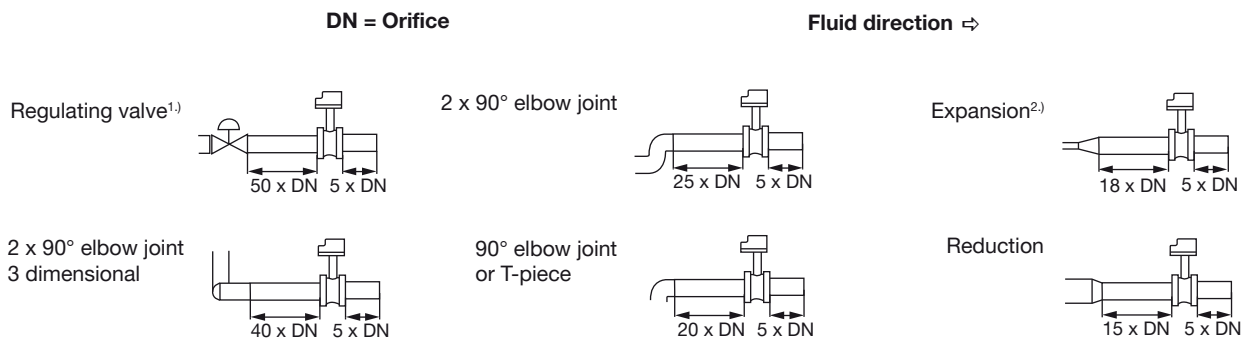

1.) If the valve cannot be mounted after the measuring device, the minimal distances have to be respected.

2.) If an expansion cannot be avoided, the minimal distances have to be respected.  
Please note minimum flow velocity

The device can be installed into either horizontal or vertical pipes.

Important criteria for this are; ensure that the measurement pipe is fully filled and that the measurement pipe is air bubble free.

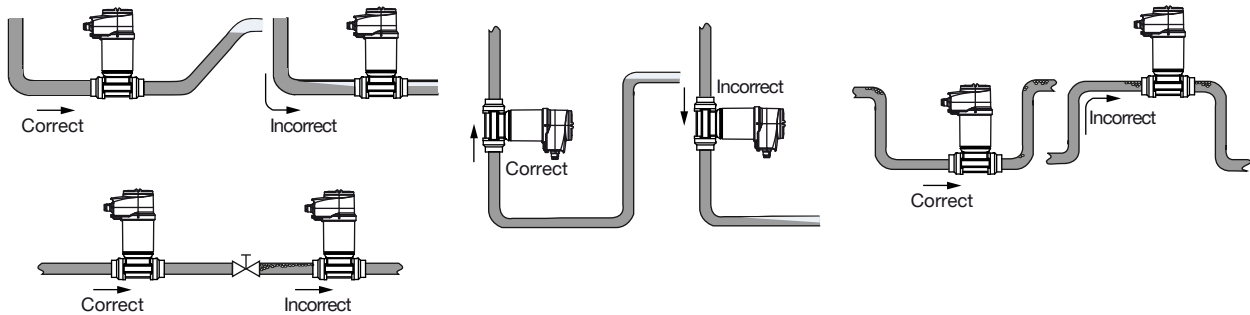

Pressure and temperature ratings must be respected according to the selected sensor-fitting material. The suitable pipe size is selected using the diagram for selecting the nominal diameter of the sensor-fitting, see **data sheet Type S030** ▶ for more information.

## 7. Product operation

### 7.1. Measuring principle

When liquid flows through the pipe, the paddle wheel with 4 inserted magnets is set in rotation, producing a measuring signal in the sensor (Hall sensor). The frequency modulated induced voltage is proportional to the flow velocity of the fluid.

A K-factor (available in the **instruction manual of the S030 fitting** ▶), specific to each pipe (size and material) enables the conversion of this frequency into a flow rate.

The electronic component converts the measured signal into several outputs (according to the flowmeter version) and displays the actual value. Totalizers are used to obtain the volume of fluid passed through the pipe.

The electrical connection is provided via one or two M12 fixed connectors.



## 8. Product design and assembly

### 8.1. Product assembly

**Note:**

- The 8036 device is made up of a compact Inline sensor-fitting (S030) equipped with a sensor with paddle wheel and an enclosure with cover containing the electronic module (transmitter SE36). A removable display/configuration module completes this flowmeter. The flowmeter can operate without the display/configuration module, but it will be required for configuration of the device (i.e. set parameters, restore default parameters, configure information to be displayed, enter access codes, adjust 4...20 mA output(s) ...) and also for visualizing continuously the measured and processed data.
- The S030 Inline sensor-fitting ensures simple installation into pipes from DN 06...DN 65. The SE36 transmitter can easily be installed into any Bürkert sensor-fitting system, by means of a quarter turn.

See **data sheet Type S030** ▶ for more information.

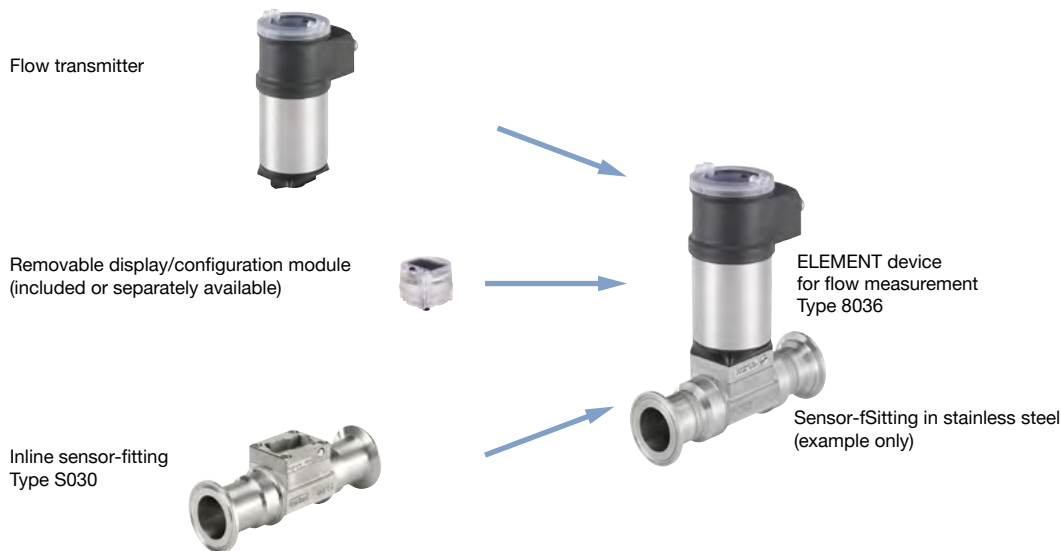

## 9. Networking and combination with other Bürkert products

**Example:**

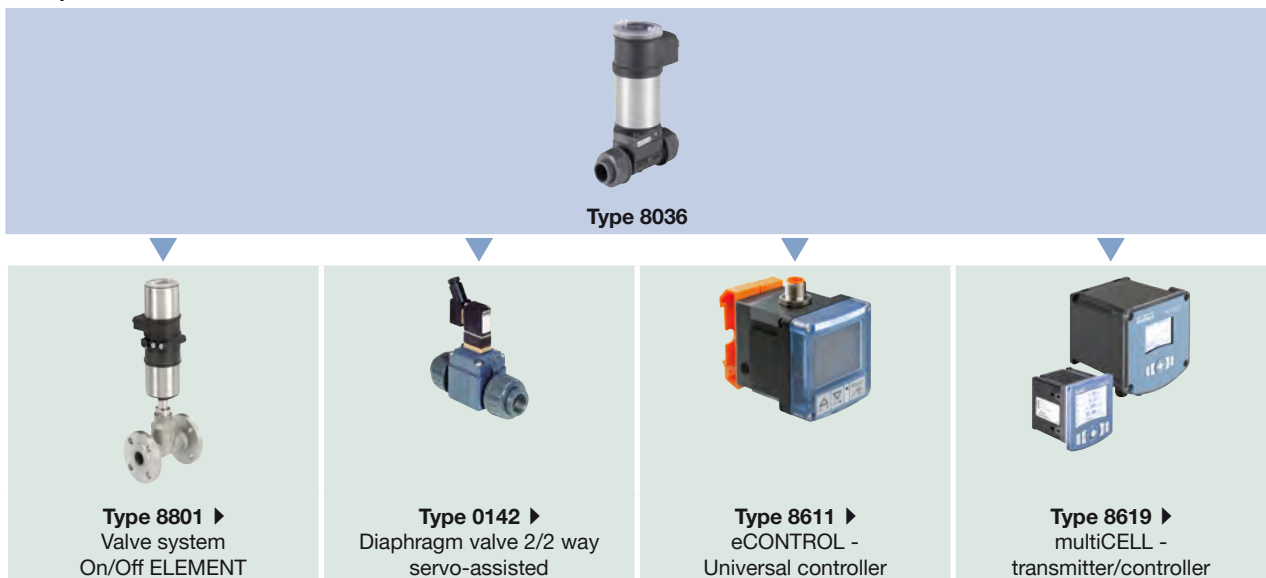

## 10. Ordering information

### 10.1. Bürkert eShop – Easy ordering and quick delivery



#### Bürkert eShop – Easy ordering and fast delivery

You want to find your desired Bürkert product or spare part quickly and order directly? Our online shop is available for you 24/7. Sign up and enjoy all the benefits.

[Order online now](#)

### 10.2. Recommendation regarding product selection

#### Note:

- A 8036 flowmeter consists of a compact SE36 flow transmitter, a removable display/configuration module and a Bürkert S030 Inline sensor-fitting.
- When you order devices without a display/configuration module, please take care that you also order at least one display/configuration module for parametrising the device (see chapter “[10.5. Ordering chart accessories](#)” on page 11).

See [data sheet Type S030](#) ▶ for more information.

Two or three different components must be ordered in order to select a complete device. The following information is required:

- **Article no.** of the compact SE36 flow transmitter available with or without display/configuration module (see chapter “[10.4. Ordering chart for flow transmitter Type SE36](#)” on page 11)
- **Article no.** of the removable display/configuration module, if necessary (see chapter “[10.5. Ordering chart accessories](#)” on page 11)
- **Article no.** of the selected S030 Inline sensor-fitting (See [data sheet Type S030](#) ▶)

### 10.3. Bürkert product filter



#### Bürkert product filter – Get quickly to the right product













You want to select products comfortably based on your technical requirements? Use the Bürkert product filter and find suitable articles for your application quickly and easily.

[Try out our product filter](#)

#### 10.4. Ordering chart for flow transmitter Type SE36







**Note:**

- All settings and digital output have to be adjusted with the optional available display/configuration module.
- All following article nos. have a transparent cover as standard.

| Operating voltage | Output   | UL certification | Electrical connection <sup>1.)</sup>                    | Article no.  |  |
|-------------------|--|------------------|---|--|--|
|                   |  |                  |   | Without display/<br>configuration<br>module  | With display/<br>configuration<br>module   |
| 14...36 V DC      | 2 outputs:<br>1 x transistor NPN<br>+ 1 x 4...20 mA (2 wires)      | –                | 5 pin M12 male fixed connector                          | 560880  | 561880  |
|                   |  | UL-Recognized    |   | 560883  | 561883  |
|                   | 3 outputs:<br>2 x transistors NPN/PNP<br>+ 1 x 4...20 mA (2 wires) | –                |   | 560881  | 561881  |
|                   |  | UL-Recognized    |   | 560884  | 561884  |
| 12...36 V DC      | 4 outputs:<br>2 x transistors NPN/PNP<br>+ 2 x 4...20 mA (3 wires) | –                | 5 pin M12 male and 5 pin M12<br>female fixed connectors | 560882  | 561882  |
|                   |  | UL-Recognized    |   | 560885  | 561885  |

1.) Order separately (see chapter "10.5. Ordering chart accessories" on page 11): M12 cable plugs (only female for one 4...20 mA output, 1 male + 1 female for two 4...20 mA outputs flowmeter)

#### 10.5. Ordering chart accessories

| Description  | Article no.  |
|--|--|
| Removable display/configuration module (with instruction sheet)  | 559168    |
| Opaque cover with seal (1 screw cover with EPDM seal + 1 quarter turn closing cover with silicone seal)      | 560948   |
| Transparent cover with seal (1 screw cover with EPDM seal + 1 quarter turn closing cover with silicone seal) | 561843  |
| 5 pin M12 female straight cable plug with plastic threaded locking ring, to be wired                         | 917116  |
| 5 pin M12 male straight cable plug with plastic threaded locking ring, to be wired                           | 560946  |
| 5 pin M12 female straight cable plug moulded on cable (2 m, shielded)  | 438680  |
| 5 pin M12 male straight cable plug moulded on cable (2 m, shielded)  | 559177  |

# Bürkert – Close to You

For up-to-date addresses  
please visit us at  
[www.burkert.com](http://www.burkert.com)

DTS 1000128709 EN Version: Q.Status: RL (released | freigegeben | validé) printed: 11.10.2021

